

HOIST FRAME COMPONENTS

ENGLISH

Key Number	Part Name	No. Req'd	Models				
			A, A-2, AA, AA-2, B, B-2, C, C-2, F, F-2	E, E-2, H, H-2	J, J-2, JJ, JJ-2, L, L-2, LL, LL-12	R, R-2, RR, RR-2	RT, RT-2, RRT, RRT-2
			Part Number				
627-101	Motor Housing Cover Gasket (Weatherproof Units Only)	1	27847		35845		
627-102	Back Frame Cover Gasket (Weatherproof Units Only)	1	27848		35840		
627-107	Motor Cover and Back Frame Cover Alignment Pins	8	—		983784		
627-108	Motor Housing Cover Screws	2	987397		987553		
627-109	Motor Housing Cover Screw Lockwashers	2					
	Standard Units		982226		982226		
	Weatherproof Units		982251		982251		
627-110	Motor Housing Cover	1					
	Orange		27597 (Includes 627-402, 446 & 447)		36071		
	Black		27059 (Includes 627-402,446, 447)		36076		
	CSA Covers w/drain slot (Orange)		27095		36023		
627-115	Motor Housing	1					
	Orange		27028C	24008C		36078	
	Black		27028B	24008B		—	
627-115A	Motor Housing Wire Way Gasket	1	28993		29002		
627-115B	Motor Housing Spacer Gasket	1	28996		29001		
627-120	Gear Housing	1					
	Orange		28669		35620		36604
	Black		28672		35627		—
627-124	Gear Housing Gasket	1	27747		35707		
627-125	Back Frame	1					
	Orange		27618 (Includes 627-123 & 627-211)		35090		
	Black		27625 (Includes 627-123 & 627-211)		35095		—
627-130	Back Frame Cover	1					
	Orange		28009C		36008C (Also order 627-445)		
	Black		28009B	36008B (Also order 627-445)			
	CSA Cover w/drain slot (Orange)		27097		36022 (Also order 627-445)		
627-131	Back Frame Cover Screw Lockwasher	As Req'd					
	Standard Units		982226 (3 Required)		982226 (4 Required)		
	Weatherproof Units		982251 (3 Required)		982251 (4 Required)		
627+132	Back Frame Cover Screw	As Req'd	87325 (3 Required)		968752 (4 Required)		
627-245	Back Frame Seal Screw		—		982623		
627-445	Capacity Label		27276 (1/8 Ton), 27277 (1/4 Ton), 27278 (1/2 Ton), 27279 (1 Ton)		35200 (1/2 Ton), 35201 (1 Ton), 35202 (2 Ton), 35203 (3 Ton)		
627-685	Series Label	1	27238		36840		
627-820	Electrical Warning Label	1	24842				

LODESTAR HOIST UPPER SUSPENSION

ENGLISH

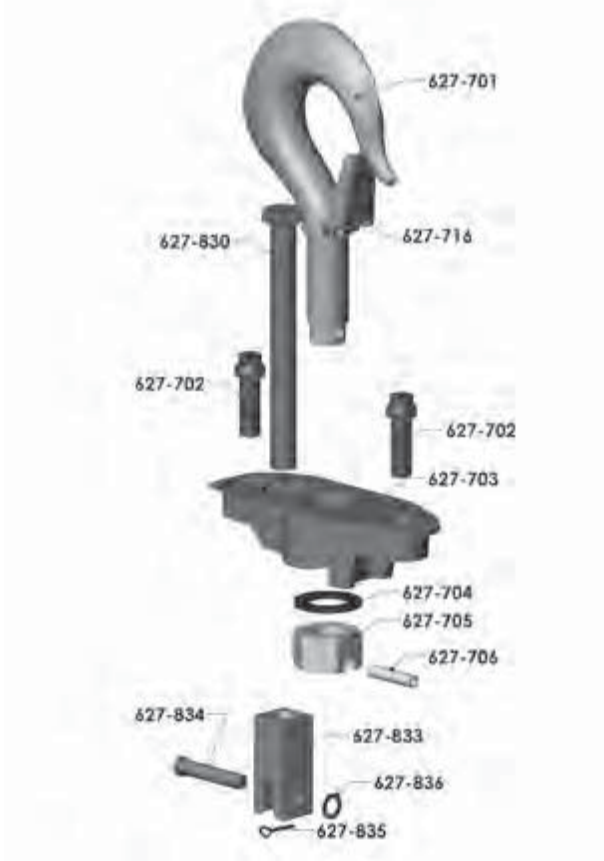

627-700
COMPLETE SWIVEL HOOK SUSPENSION

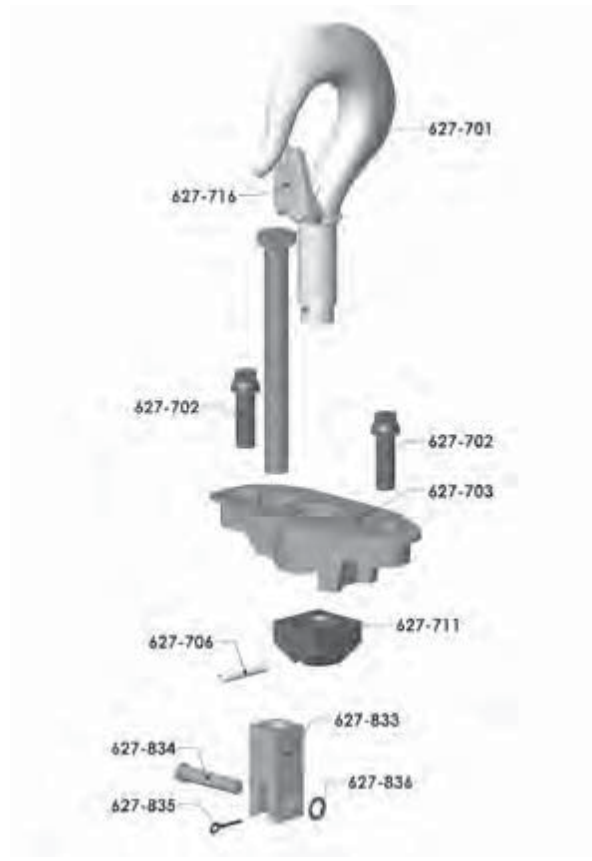

627-710
COMPLETE RIGID HOOK SUSPENSION

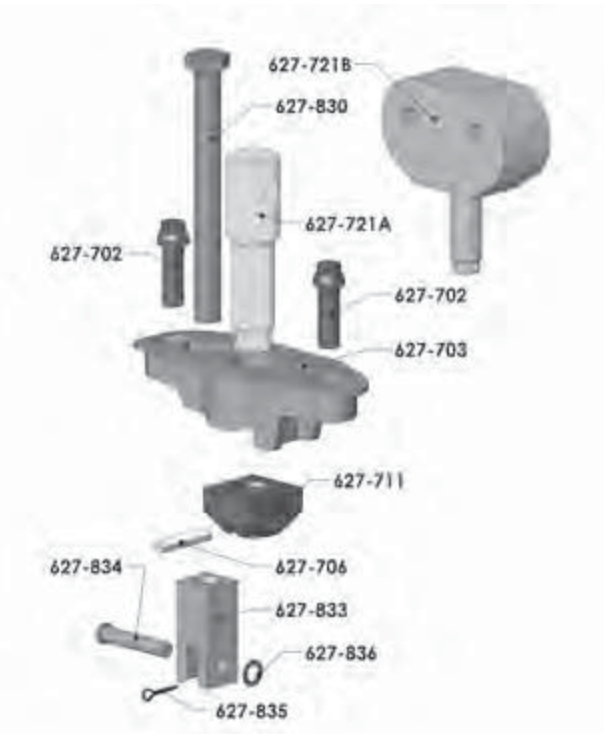

627-720
COMPLETE LUG SUSPENSION



TRIPLE REEVED SUSPENSION
& SHEAVE HANGER

UPPER SUSPENSION COMPONENTS

ENGLISH

Key Number	Part Name	No. Req'd	Models				
			A, A-2, AA, AA-2, B, B-2, C, C-2, F, F-2	E, E-2, H, H-2	J, J-2, JJ, JJ-2, L, L-2, LL, LL-12	R, R-2, RR, RR-2	RT, RT-2, RRT, RRT-2
			Part Number				
627-700	Swivel Hook Suspension (Includes 627-701 thru 627-706 for Models A, A-2, AA, AA-2, B, B-2, C, C-2, F, F-2, J, J-2, JJ, JJ-2, L, L-2, LL, & LL-2.) (Includes 627-701 thru 627-706, 627-830 & 627-833 thru 627-836 for Models E, E-2, H, H-2, R, R-2, RR & R-2) (Includes 627-701 thru 627-703, 627-705 & 627-7-6 for Models RT, RT-2, RRT & RRT-2)	1	2792 (Latch Type Hook)	2793 (Latch Type Hook)	3661 (Latch Type Hook)	3660 (Latch Type Hook)	9557 (Latch Type Hook)
627-701	Upper Hook Latch Type	1	28689	28697	35617	35616	35613
	Latchlok Type	1	28643	28602	36678	36680	36694
627-702	Suspension Adapter Screw	1	27529		35588		
627-703	Suspension Adapter	1	27003B	27013	35740B	35741B	Order Complete Suspension
627-704	Upper Hook Washer (Swivel Hook Suspension Only)	1	27786	45930	45930	45918	—
627-705	Upper Hook Collar Nut (Swivel Hook Suspension Only)	1	27350	45385	35042	35041	36352
627-706	Upper Hook or Suspension Lug Pin (Special Alloy Steel) Specify for Rigid or Swivel Type Suspension	1	27805	45941	983763 (Rigid)	983761 (Rigid)	983762
					983764 (Swivel)	983762 (Swivel)	
627-710	Rigid Hook Suspension (Includes 627-701 thru 627-703, 627-706 & 627-711 for Models A, A-2, AA, AA-2, B, B-2, C, C-2, F, F-2, J, J02, JJ, JJ-2, L, L-2, LL, & LL-2) (Includes 627-702, 627-703, 627-706, 627-711, 627-733, 627-830 & 627-833, thru 627-836 for Models E, E02, H, H-2, R, R-2, RR & R-2. (Includes 627-702, 627-703, 627-706, 627-711, 627-728, 627-729 thru 627-730 for Models RT, RT-2, RRT & RRT-2		*2788 (Latch Type Hook)	*2789 (Latch Type Hook)	*3651 (Latch Type Hook)	*3658 (Latch Type Hook)	*9559 (Latch Type Hook)
627-711	Upper Hook or Suspension Lug Collar (For Rigid Hook and Lug Suspension)	1	27361	27370	35458	35479	**36360
627-716	Latch Kit	1	45661	45662	45662	45663	45663
627-720	Lug Suspension (Includes 627-702, 627-703, 627-706 & 627-711 & 627-721A for Models A, A-2, AA, AA-2, B, B-2, C, C-2, F, F02, J, J-2, JJ, JJ-2, L, L-2, LL, & LL-2 (Includes 627-702, 627-703, 627-706, 627-711, 627-721A, 627-830 & 627-823 thru 627-836 for Models E, E-2, H, H-2, R, R-2, RR & RR-2) (Includes 627-702, 627-703, 627-7-6, 627-711, 627-728, 627-729 and 627-730 for Models RT, RT-2, RRT & RRT-2	1	2778 for Series 635 Low Headroom Trolley	2779 for Series 635 Low Headroom Trolley	3677 for Series 635 Low Headroom Trolley	3668	9561
			2992 for Series 635 Motor Driven Trolley	2993 for Series 635 Motor Driven Trolley	3679 for Series 635 Motor Driven Trolley		
627-721A	Suspension Lug For Series 635 Low Headroom Trolley		27450	27452	35456	35457	
	For Series 635 Motor Driven Trolley		27454	27455	35459	35457	
627-721B	Suspension Lug	1	Contact Factory				
	Special High Strength Bolts, Grade 6 or better required for attachment	1					C246
627-723	Cloverleaf Plate & Attaching Screws						C247
627-724	Sheave Stud 2/washer, Slotted Nut, Seat and Retainer Pin						36011
627-725	Sheave Hanger						88429
627-726	Sheave Hanger Bearing						36350
627-727	Upper Sheave						Order Complete Suspension
627-728	Suspension Lug						Order Complete Suspension
627-729	Shackle w/Pin and Retainer Rings						C248
627-730	Suspension Lug Pin w/Retainer Pins						40740
627-731	Bearing Retainer Ring						
627-830	Dead End Bolt (Special Alloy)	1		89508		35957	
627-833	Dead End Block	1		27397		35418	
627-834	Dead End Pin	1		82320		82314	
627-835	Dead End Pin Cotter Pin	1		988330		988330	
627-836	Dead End Pin Washer	1		987878		987877	



LODESTAR LOWER HOOK BLOCK ASSEMBLY

ENGLISH

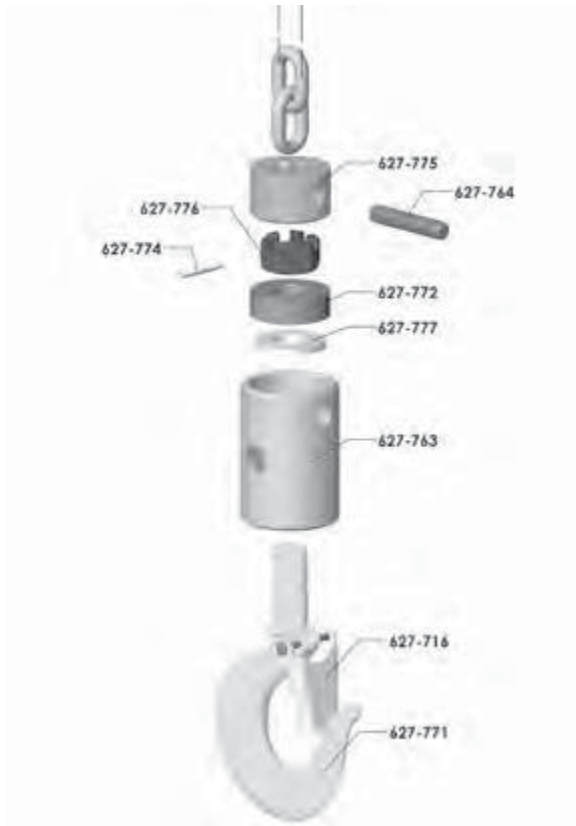

627-760
COMPLETE SINGLE REEVED
LOWER HOOK BLOCK ASSEMBLY

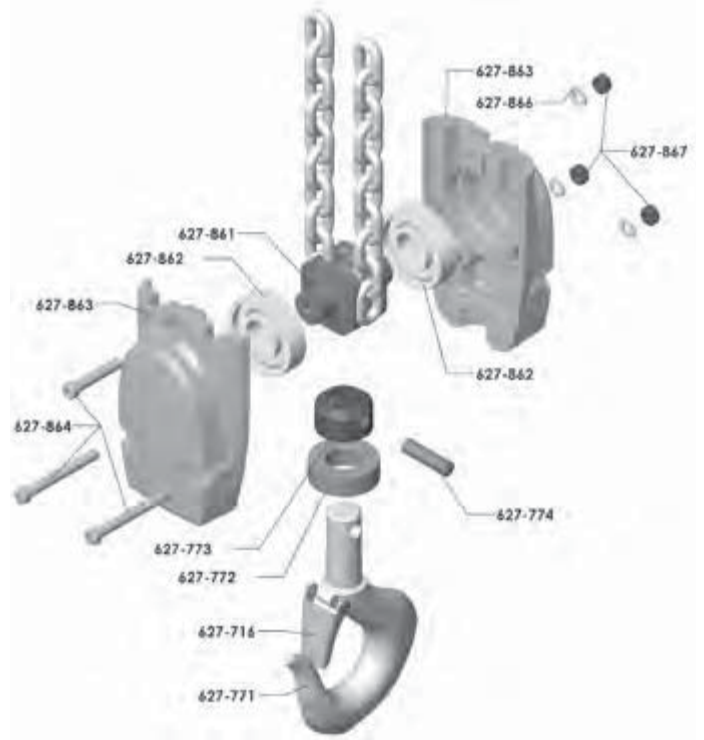

627-860
COMPLETE DOUBLE REEVED
LOWER HOOK BLOCK ASSEMBLY

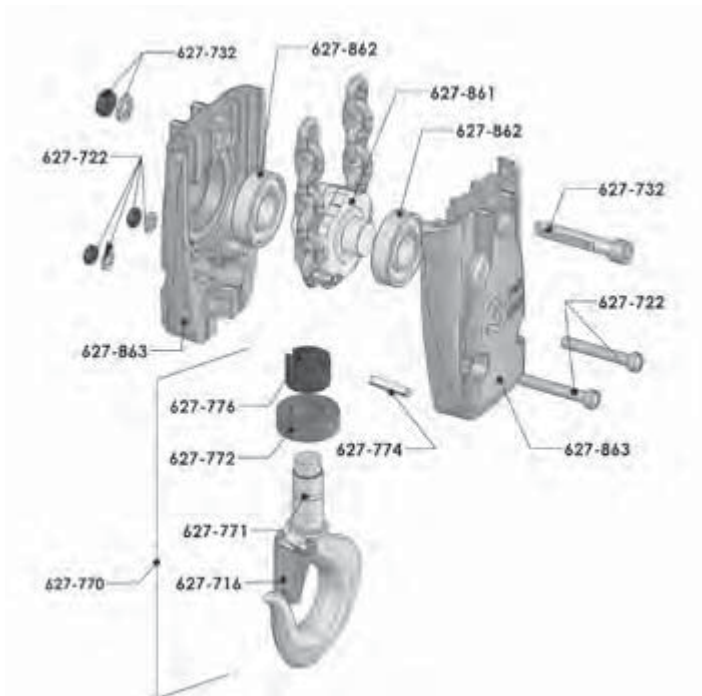

627-860
TRIPLE REEVED
LOWER HOOK BLOCK ASSEMBLY

LOWER HOOK BLOCK ASSEMBLY

ENGLISH

Key Number	Part Name	No. Req'd	Models				
			A, A-2, AA, AA-2, B, B-2, C, C-2, F, F-2	E, E-2, H, H-2	J, J-2, JJ, JJ-2, L, L-2, LL, LL-12	R, R-2, RR, RR-2	RT, RT-2, RRT, RRT-2
			Part Number				
627-716	Latch Kit (specify no. req'd)	—	45661	45662	45662	45663	45663
627-722	Hook Block Screws with Nuts and Lockwasher (2 Each)	1	—				C245
627-732	Dead End Screw with Nut and Lockwasher	1	—				C249
627-760	Lower Hook Block Assembly	1	**28683	—	35651	—	36607
627-763	Lower Hook Body	1	45401B	—	35370	—	
627-764	Lower Hook Chain Block Pin	1	45943	—	35790	—	
627-770	Lower Hook Block Assembly	1	—	*28665	—	*35645	*36606
627-771	Lower Hook with Latch: Latch Type Hook	1	28686	28687	35611	35612	36606
	Latchlok Type Hook	1	28604	28603	28604	36681	***
	All Other Hook Types	1	Contact Factory				
627-772	Lower Hook Thrust Bearing	1	88485	88478	88485	88505	8850
627-773	Lower Hook Collar	1	—	27359	—	35478	—
627-774	Lower Hook Pin	1	983772	45941	983772	45946	983762
627-775	Lower Hook Chain Block	1	28007	—	35026	—	
627-776	Lower Hook Nut	1	982526	—	982526	—	36352
627-777	Lower Hook Block Washer	1	945921	—	945921	—	
627-833	Dead End Block	1	—	27397	—	35418	—
627-834	Dead End Pin	1	—	82320	—	82314	—
627-835	Dead End Pin Cotter Pin	1	—	988330	—	988330	—
627-836	Dead End Pin Washer	1	—	987878	—	987877	—
627-837	Contact Block	1	—	—	—	36764	—
627-860	Lower Hook Block Assembly-Complete	1	—	**28685-	—	**0000277B	*36607
627-861	Hook Block Sheave	1	—	27017	—	00000274	36351
627-862	Hook Block Sheave Bearing	2	—	88429	—	83674	83670
627-863	Hook Block (Order in Pairs)	2	—	27048	—	36032	36010
627-864	Hook Block Screw-Long	2	—	982066	—	982374	—
627-865	Hook Block Screw-Short	1	—	986191	—	982370	—
627-866	Hook Block Screw L.W.	3	—	940802	—	940830	—
627-867	Hook Block Screw Nut	3	—	982514	—	982445	—

*Contact CM for Part Number of Suspension with Latchlok Type Hook.

**Latch Type Hook. Contact CM for Part Number of Lower Hook and Body with Latchlok Type Hook.

***For Swivel Hook Nut, Part Number is 36352.

LODESTAR HOIST CONTROL END COMPONENTS

MODELS A, A-2, AA, B, B-2, C, C-2, E, E-2, F, F-2, H, H-2

ENGLISH

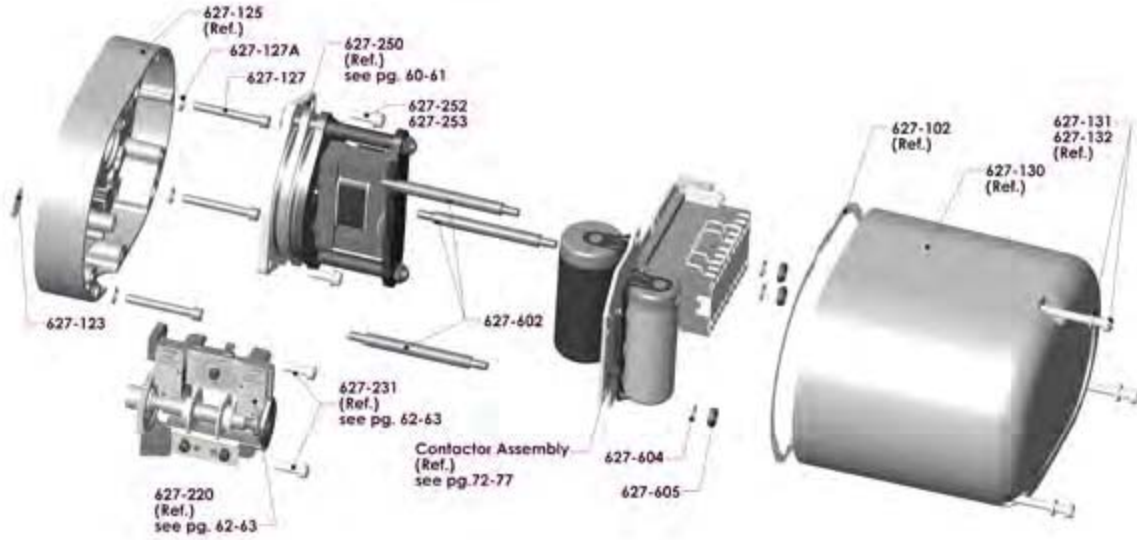

MODELS J, J-2, JJ, JJ-2, L, L-2, LL, LL-2, R, R-2, RR, RR-2, RT, RT-2, RRT, RRT-2

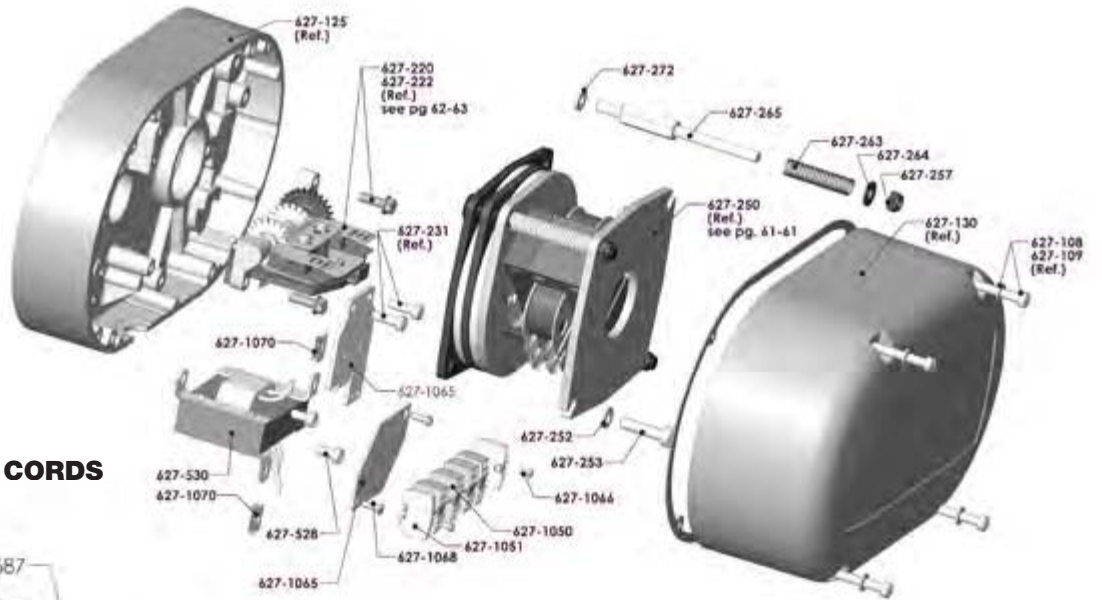

CONTROL AND POWER CORDS

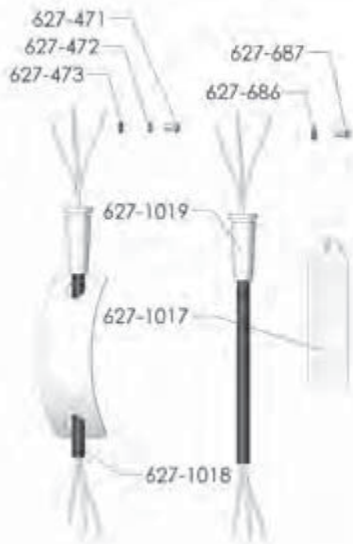

CONTROL END COMPONENTS

ENGLISH

Key Number	Part Name	No. Req'd		Models					
				A, A-2, AA, AA-2, B, B-2, C, C-2, F, F-2	E, E-2, H, H-2	J, J-2, JJ, JJ-2, L, L-2, LL, LL-12	R, R-2, RR, RR-2	RT, RT-2, RRT, RRT-2	
				Part Number					
627-123	Back Frame Expansion Plug	1		940837					
627-127	Back Frame Attaching Screw	3	4	982699			982682		
627-127A	Back Frame Attaching Screw Lockwasher	3	4	940802			940802		
627-128	Back Frame Attaching Screw	2		—	—		982698 (1 3/4" lg.)		
627-128A	Back Frame Attaching Screw Lockwasher	2		—	—		940830		
627-129	Back Frame Attaching Screw	2		—	—		987322 (2" lg)		
627-129A	Back Frame Attaching Screw Lockwasher	2		—	—		940830		
627-220	Limit Switch Shaft & Gear Kit	1		—	—		36641 (See Separate Parts List on Page 64)		
	Rotatable Limits			—	—		36656 (See Separate Parts List on Page 64)		
627-222	Limit Switch Kit	1		—	—		31636 (See Separate Parts List on Page 64)		
627-250	Electric Brake Assembly - Complete	1		See Separate Parts List on Page 62-63					
627-252	Brake Attaching Screw Lockwasher	—		982226 (2 Req'd)			945851 (1 Req'd)		
627-253	Brake Attaching Screw	—		982708 (2 Req'd)			982709 (1 Req'd)		
627-257	Brake Stud Nut	2					945840		
627-263	Hex Brake Stud Spring	1		57753			35831		
627-264	Hex Brake Stud Spring Washer	1		—	—		954807		
627-265	Hex Brake Stud	1		—	—		36674		
627-272	Hex Brake Stud Lockwasher	1		—	—		982232		
627-471	Control Cord Attaching Screw	1					987827		
627-472	Control Cord Attaching Screw Washer	1					927835		
627-473	Control Cord Attaching Screw Lockwasher	1					982226		
627-528	Transformer Attaching Screw	2		—	—		982688		
627-530	Transformer:	1		See page 72-77					
	220/230 Volt Primary w/115 Volt Secondary							29070	
	220/230 Volt Primary w/48 Volt Secondary							29071	
	220/230 Volt Primary w/24 Volt Secondary							29072	
	220/230 Volt Primary w/115 Volt Secondary with Thermal Cutout for CSA							29075	
	220/230 Volt Primary w/48 Volt Secondary with Thermal Cutout for CSA							29076	
	220/230 Volt Primary w/24 Volt Secondary with Thermal Cutout for CSA							29077	
	110/115 Volt Primary w/48 Volt Secondary							29073	
	110/115 Volt Primary w/24 Volt Secondary							29074	
	110/115 Volt Primary w/48 Volt Secondary with Thermal Cutout for CSA							29078	
	110/115 Volt Primary w/24 Volt Secondary with Thermal Cutout for CSA							29079	
627-602	Contacting Mounting Plate Stud	3		27836			—		
627-604	Contacting Mounting Plate Stud Lockwasher	3		982226			—		
627-605	Contacting Mounting Plate Stud Nut	3		982514			—		
627-686	Power Cord Attaching Screw	1					987827		
627-687	Power Cord Attaching Screw Lockwasher	1					982226		
627-1017	Instruction Tag	1		29271 (Dual Voltage), 927992 (Single Voltage)					
627-1018	Power Cord	1		29924 (Single Phase Units) 29925 (220/230-1-50/60 Units) 27589 (Three Phase)			29042 (Single Phase Units) 29430 (Three Phase Units)		
627-1019	Control Cord Assembly	1		See Separate parts list on Pages 86-88					
627-1050	Terminal Strip	4					39460*		
627-1051	Terminal Strip End Clamp	2					39452*		
627-1065	Terminal Strip Mounting Bracket	1					31639* (220/230-1-50/60 & 110 volt Single Phase w/Transformers)		
							29012 All Other Units		
627-1066	Terminal Strip Mounting Screw	2		—			951726*		
627-1067	Terminal Strip Mtg. Screw Lockwasher	2					957855*		
627-1068	Terminal Strip Mtg. Bracket Screws	2					958805*		
627-1069	Terminal Strip Mtg. Bracket Screw Lockwasher	2					987873*		
627-1070	Terminal Strip Mtg. Bracket Screw Nut	2					988141*		



LODESTAR HOIST BRAKE COMPONENTS

MODELS A, A-2, AA, B, B-2, C, C-2, E, E-2, F, F-2, H, H-2

ENGLISH

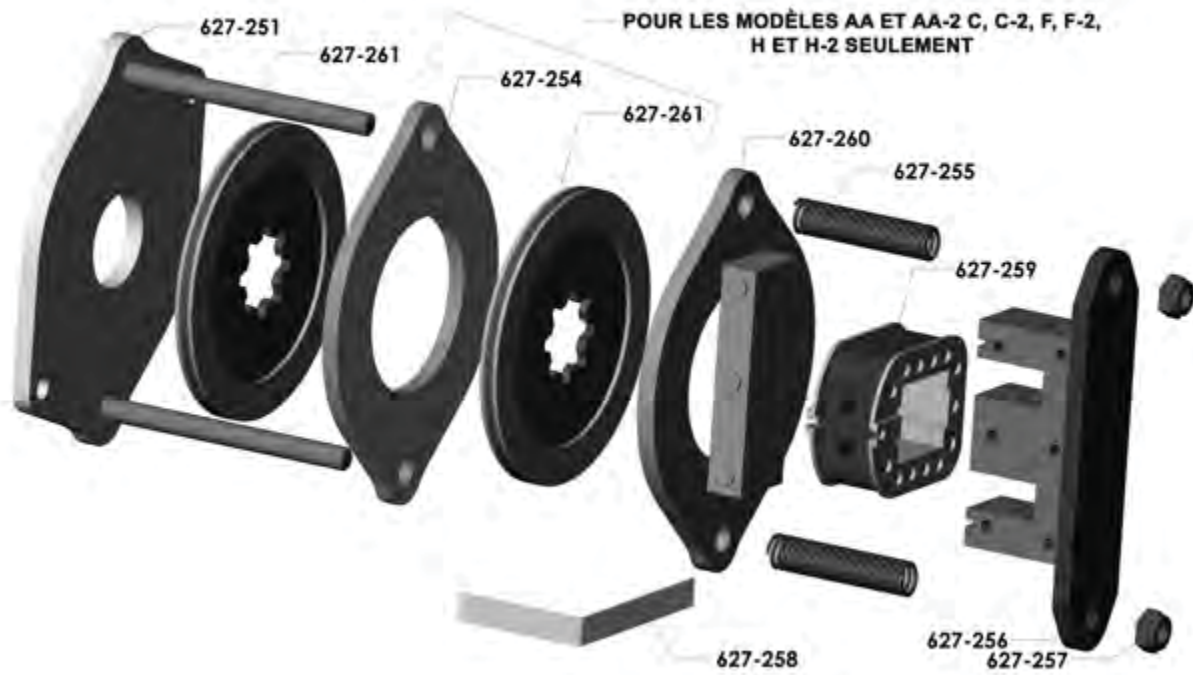

MODELS J, J-2, JJ, JJ-2, L, L-2, LL, LL-2, R, R-2, RR, RR-2, RT, RT-2, RRT, RRT-2

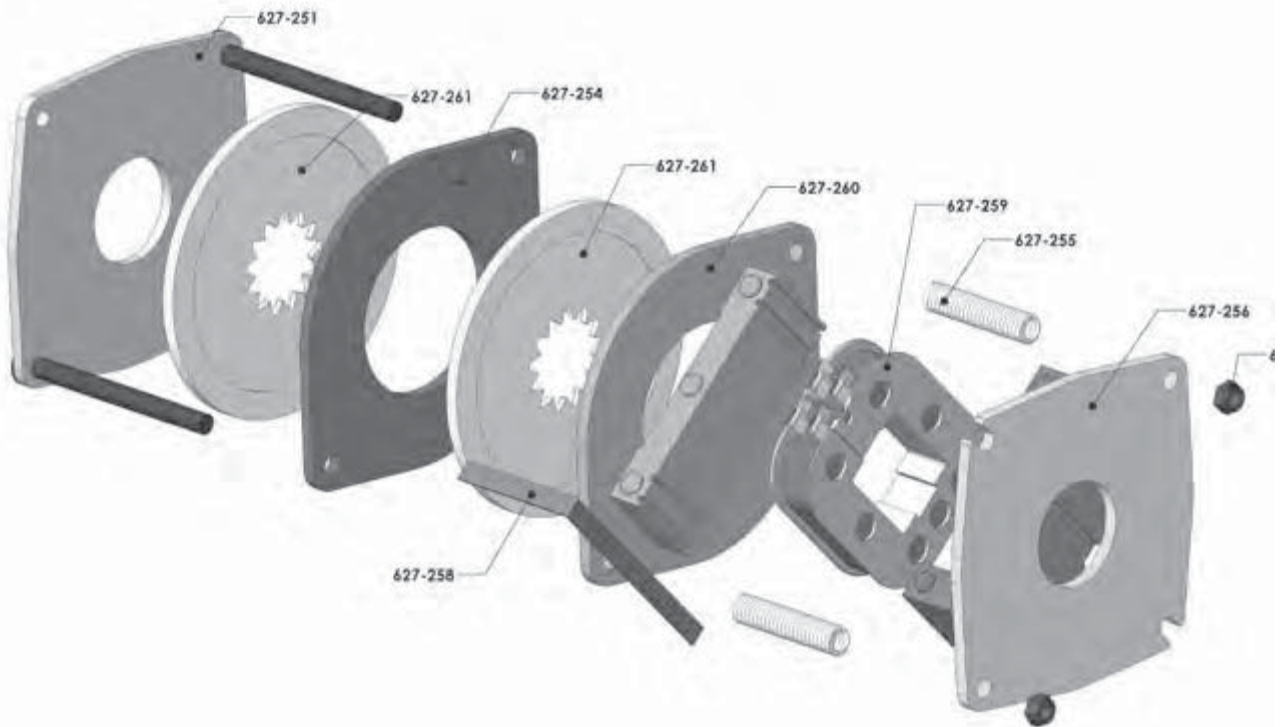

BRAKE COMPONENTS

Key Number	Part Name	No. Req'd	Models	
			A, A-2, AA, AA-2, B, B-2, C, C-2, F, F-2, H, H-2	J, J-2, JJ, JJ-2, L, L-2, LL, LL-2, R, R-2, RR, RR-2, RT, RT-2, RRT, RRT-2
			Part Number	
627-251	Brake Base Plate and Studs	1	28668	35643
627-254	Brake Intermediate Plate	1	27091 (For Models AA, AA-2, C, C-2, F, F-2, H & H-2 only)	35069
627-255	Brake Spring	2	27751 (Color Coded Blue)	35716 (Color Coded Yellow for Models J, J-2, L-2, R, R-2, RT and RT-2) 35717 (Color Coded Green for Models JJ, JJ-2, LL, LL-2, RR, RR-2, RRT and RRT-2)
627-256	Brake Field Sub-Assembly	1	28677 (Includes 627-262)	35629
627-257	Brake Stud Nut	2	345840	
627-258	Brake Coil Retainer Strap	1	57753	35704
627-259	Brake Coil	1	See Separate Listing on Page 51	
627-260	Brake Armature Assembly	1	28678	35600 (Includes 627-262)
627-261	Brake Friction Disc	—	27677 (1 Req'd for Models A, A-2, B, B-2, E, E-2) (2 req'd for Models AA, AA-2, C, C-2, F, F-2, H, H-2)	35632 (2 Req'd)

ENGLISH

LODESTAR HOIST LIMIT SWITCH COMPONENTS

MODELS A, A-2, AA, B, B-2, C, C-2, E, E-2, F, F-2, H, H-2

ENGLISH

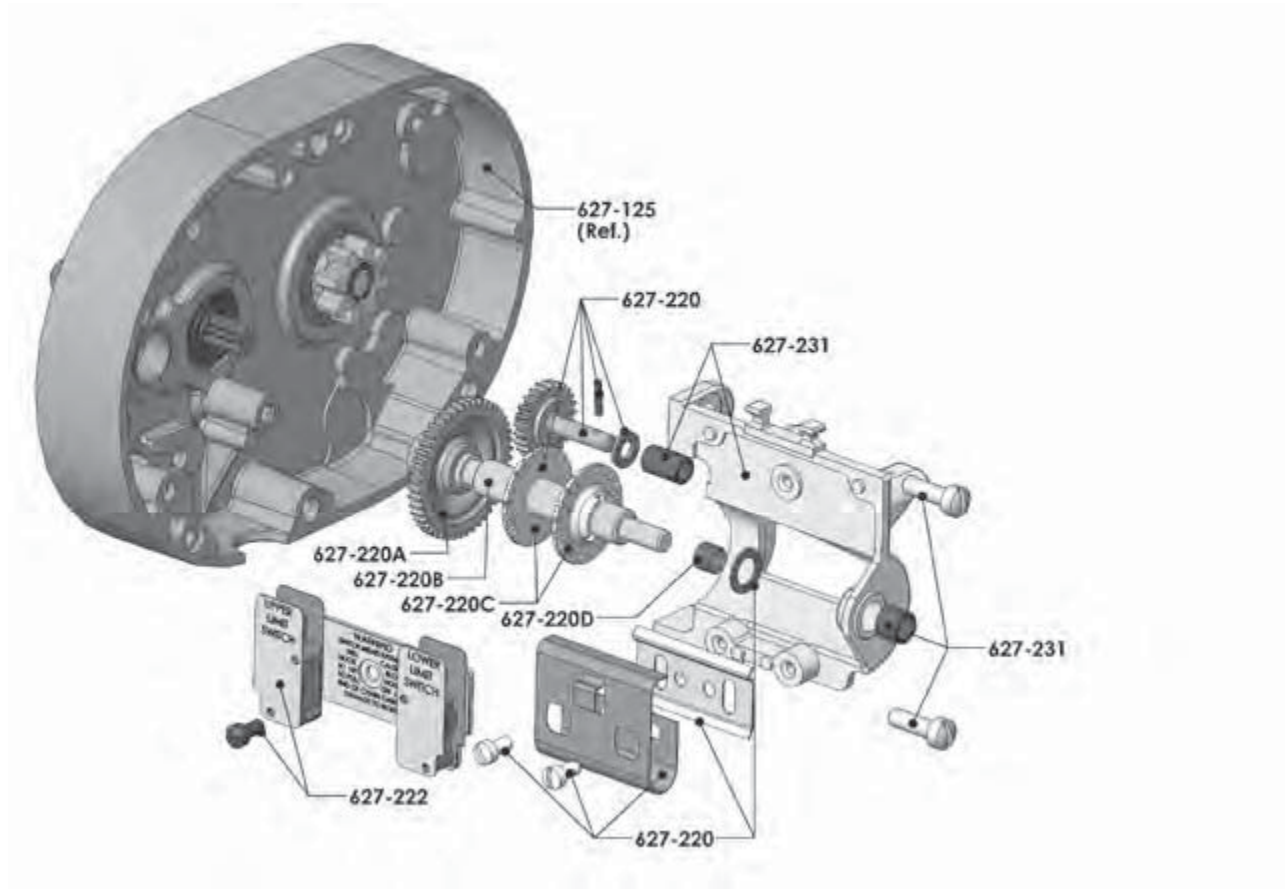

MODELS J, J-2, JJ, JJ-2, L, L-2, LL, LL-2, R, R-2, RR, RR-2, RT, RT-2, RRT, RRT-2

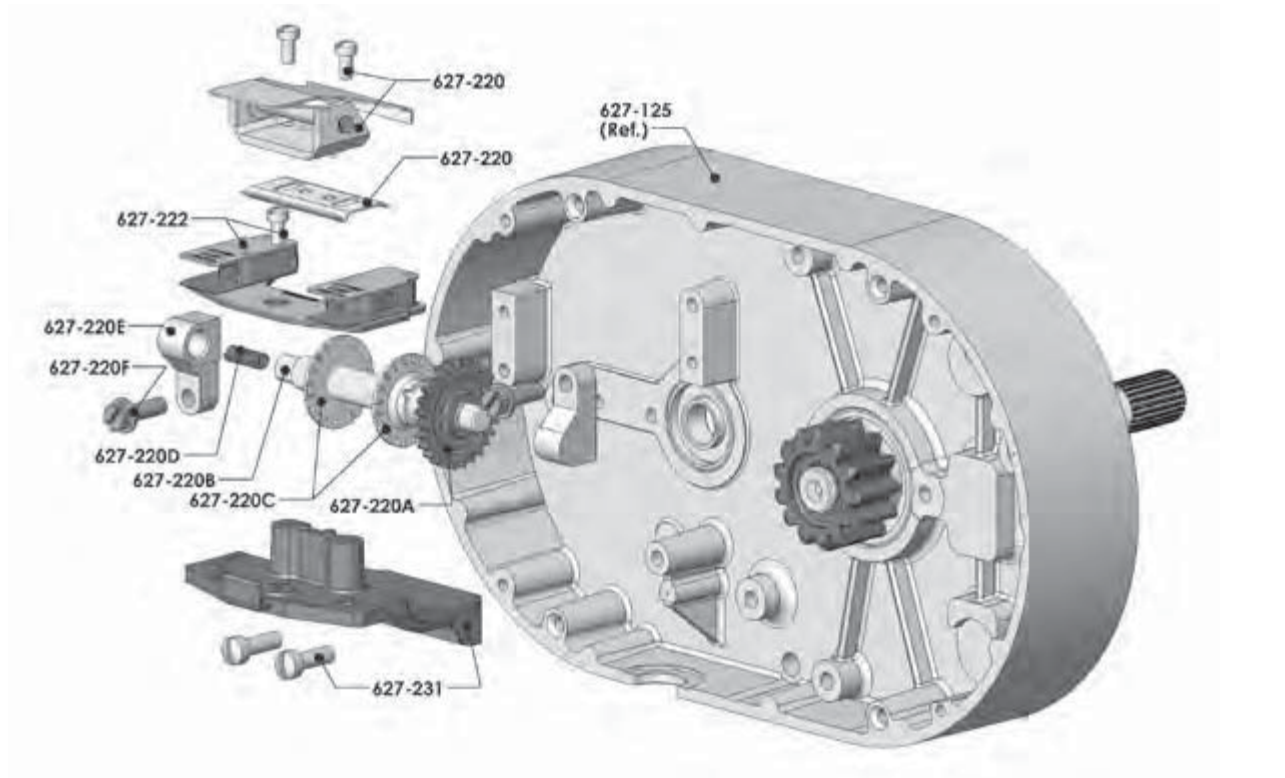

LIMIT SWITCH COMPONENTS

Key Number	Part Name	No. Req'd	Models	
			A, A-2, AA, AA-2, B, B-2, C, C-2, F, F-2, H, H-2	J, J-2, JJ, JJ-2, L, L-2, LL, LL-2, R, R-2, RR, RR-2, RT, RT-2, RRT, RRT-2
			Part Number	
627-220	Limit Switch Shaft and Gear Kit	1	27561	36641
	Rotatable Limit Switch		27749	36656
627-220A	Limit Switch Gear	1	27714	35753
627-220B	Limit Switch Shaft (44 thread)	1	70399	36373
	Limit Switch Shaft (56 thread)		27307	36317
	Limit Switch Shaft (64 thread)		27251	36321
627-220C	Travel Nut (44 thread)	2	70053	70053
	Travel Nut (56 thread)		36318	36318
	Travel Nut (64 thread)		36319	36319
627-220D	Spring	1	28712	35703
627-220E	Limit Switch Bearing	2	—	35751
627-220F	Mounting Screws	2	—	983656
627-222	Limit Switch Kit: Three Phase	1	31631	31636
	All Others		31631	
627-231	Limit Switch Bracket Sub-Assembly	1	27502	36644

LODESTAR HOIST GEARING COMPONENTS

MODELS A, A-2, AA, B, B-2, C, C-2, E, E-2, F, F-2, H, H-2

ENGLISH

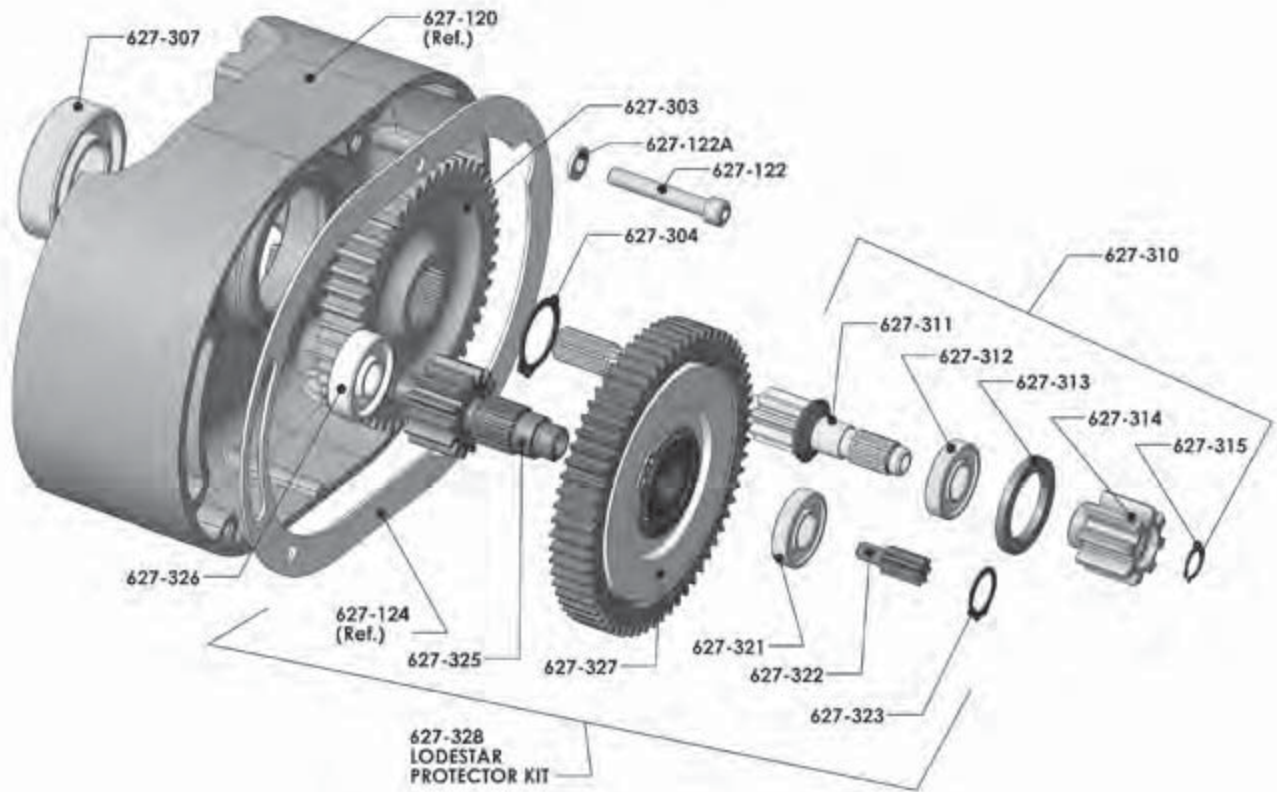

MODELS J, J-2, JJ, JJ-2, L, L-2, LL, LL-2, R, R-2, RR, RR-2, RT, RT-2, RRT, RRT-2

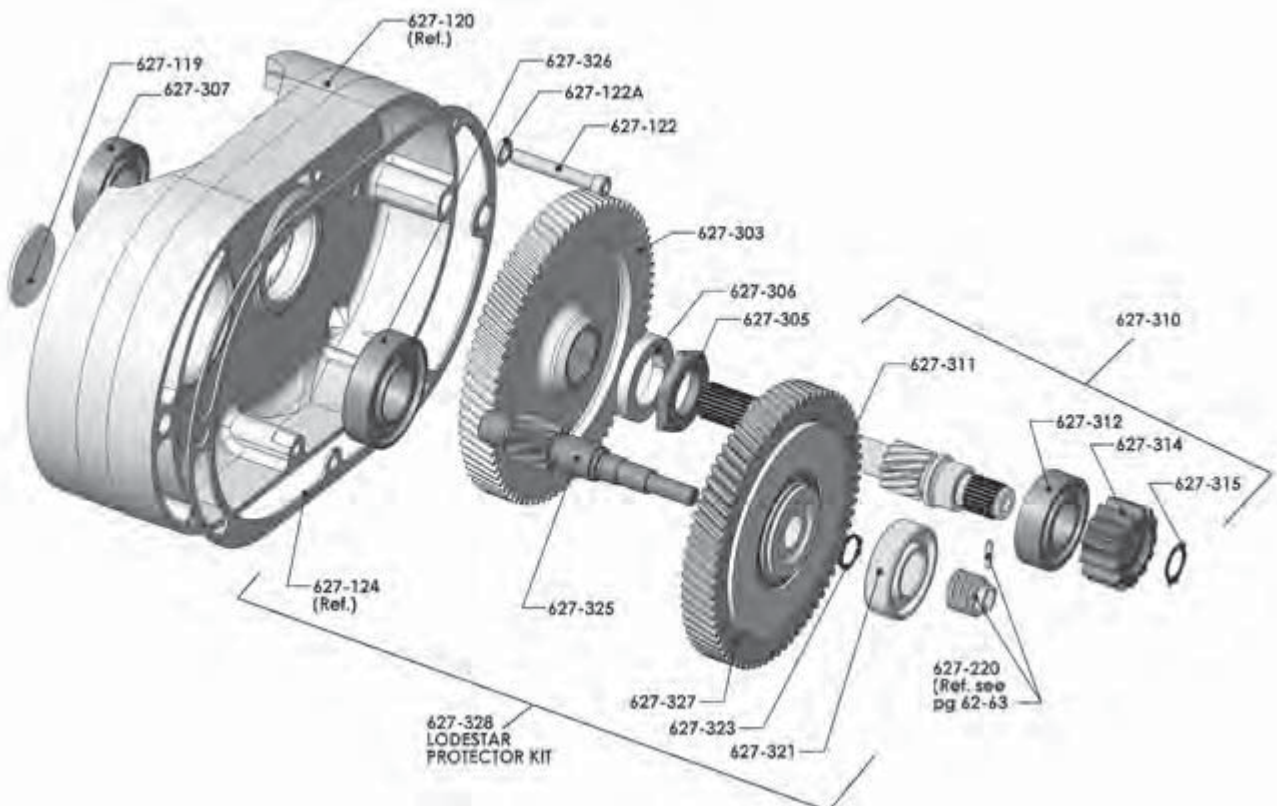

GEARING COMPONENTS

ENGLISH

Key Number	Part Name	No. Req'd	Models	
			A, A-2, AA, AA-2, B, B-2, C, C-2, F, F-2, H, H-2	J, J-2, JJ, JJ-2, L, L-2, LL, LL-2, R, R-2, RR, RR-2, RT, RT-2, RRT, RRT-2
			Part Number	
627-119	Gear Housing Plug	1	—	935495
627-122	Gear Housing Attaching Screw	4	28830	982682
627-122A	Gear Housing Attaching Screw Lockwasher	4	940802	940830
627-303	Liftwheel Gear	1	27010 (47 teeth) Models A, A-2, C & C-2 28380 (39 teeth) Models AA & AA-2 27009 (56 teeth) Models B, B-2, E, E-2, F, F-2, H & H-2	35009 (79 teeth) Models J, J-2, L, L-2, R, R-2, RT & RT-2 35639 (60 teeth) Models JJ, JJ-2, LL, LL-2, RR, RR-2, RRT & RRT-2
627-304	Liftwheel Gear Snap Ring	1	27767	—
627-305	Liftwheel Gear Nut	1	—	35773
627-306	Liftwheel Gear Nut Washer	1	—	986576
627-307	Liftwheel Bearing-Gear End	1	88429	82002
627-310	Drive Shaft and Pinion Sub Assembly (Includes items 627-311 thru 627-315 as applicable)	1	27654 (5-43/64" lg. shaft length) Models AA, AA-2, C, C-2, F, F-2, H & H-2 27653 (5 15/64" lg shat length) Models A, A-2, B, B-2, E & E-2	35688 (18 teeth pinion & 13 teeth hub) Models J, J-2, JJ & JJ-2 35687 (12 teeth pinion & 15 teeth hub) Models L, L-2, LL, LL-2, R, R-2, RR, RR-2, R, RT, RT-2, RRT & RRT-2
627-311	Drive Shaft and Pinion		C204 (Models AA, AA-2, C, C-2, F, F-2, H & H-2) C203 (Models A, A-2, B, B-2, E & E-2)	35357 (18 teeth) Models J, J-2, JJ & JJ2 35356 (12 teeth) Models L, L-2, LL, LL-2, R, R-2, RR, RR-2, RT, RT-2, RRT & RRT-2
627-312	Drive Shaft and Pinion Bearing	1	82009	83691
627-313	Drive Shaft and Pinion Bearing Spacer	1	27710	—
627-314	Brake Hub	1	27852 (1 1/2 lg.) Models AA, AA-2, C, C-2, F, F-2, H & H-2 27851 (2 1/32 lg) Models A, A-2, B, B-2, E & E-2	35744
627-315	Brake Hub Snap Ring	1	27765	35766
627-321	Intermediate Gear and Pinion Bearing Outboard End	1	82009	88437
627-322	Limit Switch Drive Pinion	1	27712	—
627-323	Intermediate Gear Snap Ring	1	27765	35763
627-325	Intermediate Pinion	1	28624 (14 teeth) Models A, A-2, C & C-2 28625 (22 teeth) Models AA & AA-2 28623 (8 teeth) Models B, B-2, E, E-2, F, F-2, H, & H-2	35351 (10 teeth) Models J, J-2, L, L-2, R, R-2, RT & RT-2 35420 (15 teeth) Models JJ, JJ-2, LL, LL-2, RR, RR-2, RRT & RRT-2
627-326	Intermediate Gear and Pinion Bearing Inboard End	1	88440	Order (1) bearing 83670 and (1) Shaft Adapter 24350
627-327	Lodestar Protector	1	28694 (for Models A, A-2, B, B-2, E & E-2) 28693 (for Models AA & AA-2) 28695 (for Models C, C-2, F, F-2, H & H-2)	36668 (for Models J & J-2) 36669 (for Models JJ & JJ-2) 36670 (for Models L, L-2, R, R-2, RT & RT-2) 36671 (for Models LL, LL-2, RR, RR-2, RRT & RRT-2)
627-328	Lodestar Protect Kit (Includes item 627-124, 627-321, 627-322, 627-323, 627-325 & 627-327 for Models A, A-2, AA, AA-2, B, B-2, C, C-2, C-2, E, E-2, F, F-2, H & H-2) (Includes items 627-124, 627-321, 627-323, 627-325 & 627-327 for Models J, J-2, L, L-2, R, R-2, RT & RT-2. (Includes items 627-124, 627-323 & 627-327 for Models JJ, JJ-2, LL, LL-2, RR, RR-2, RRT & RRT-2	1	2876 (for Models A & A-2) 2877 (for Models AA & AA-2) 2878 (for Models B, B-2, E & E-2) 2879 (for Models C & C-2) 2880 (for Models F, F-2, H & H-2)	3601 (for Models J & JJ-2) 3602 (for Models JJ & JJ-2) 3603 (for Models L, L-2, R, R-2 RT & RT-2) 3604 (for Models LL, LL-2, RR, RR-2 RRT & RRT-2)

LODESTAR HOIST LIFTWHEEL COMPONENTS

MODELS A, A-2, AA, B, B-2, C, C-2, E, E-2, F, F-2, H, H-2

ENGLISH

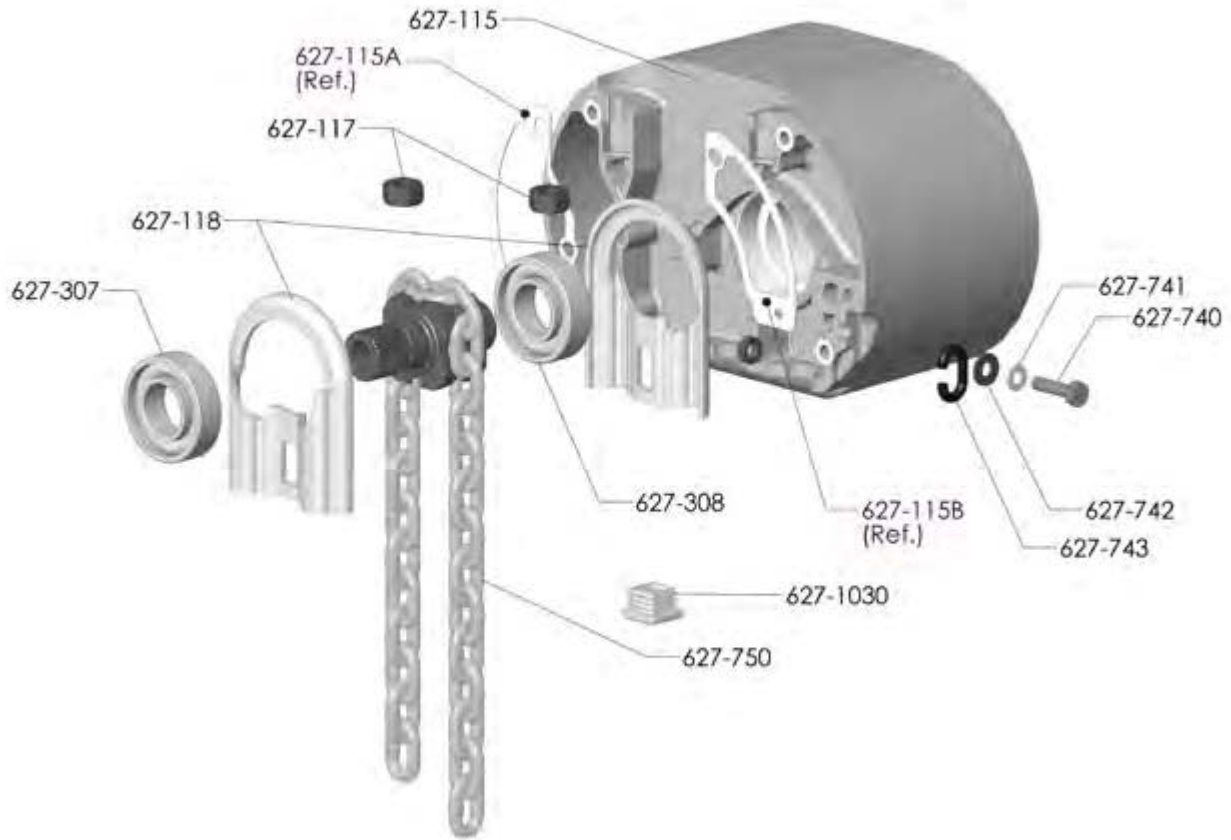

MODELS J, J-2, JJ, JJ-2, L, L-2, LL, LL-2, R, R-2, RR, RR-2, RT, RT-2, RRT, RRT-2

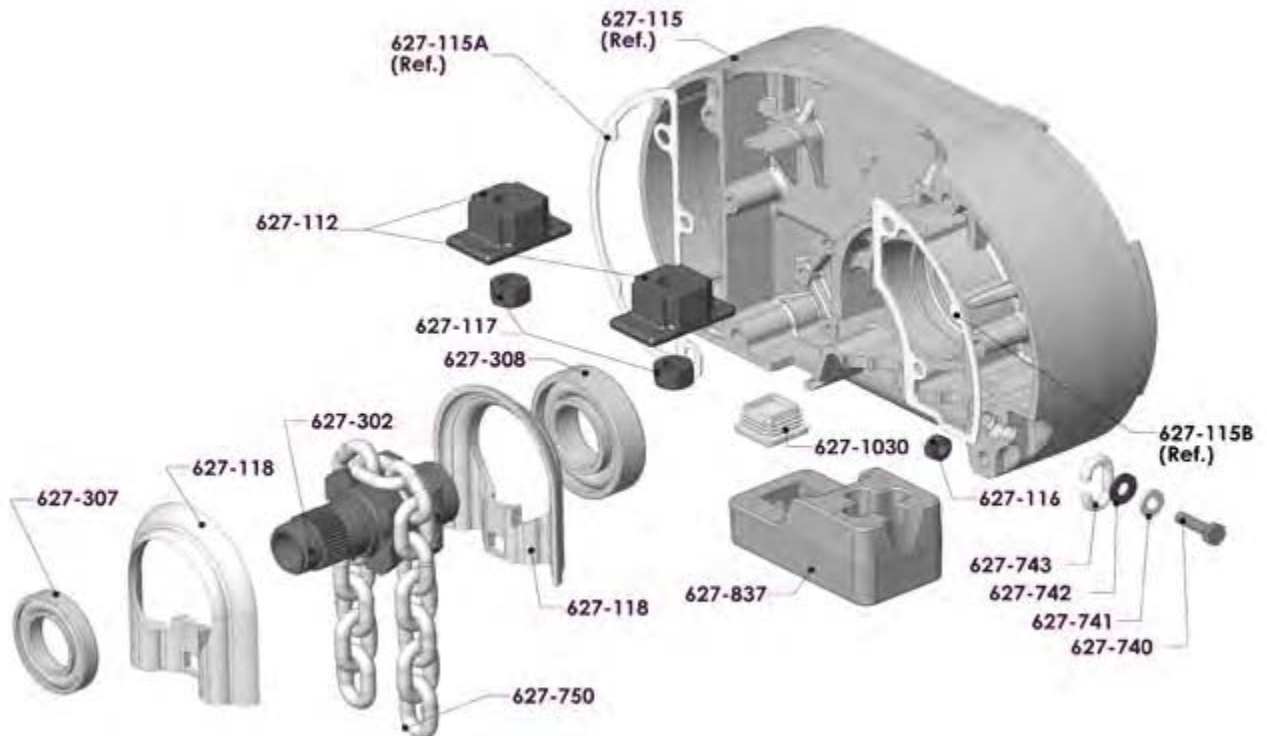

LIFTWHEEL COMPONENTS

Key Number	Part Name	No. Req'd	Models				
			A, A-2, AA, AA-2, B, B-2, C, C-2, F, F-2	E, E-2, H, H-2	J, J-2, JJ, JJ-2, L, L-2, LL, LL-12	R, R-2, RR, RR-2	RT, RT-2, RRT, RRT-2
			Part Number				
627-112	Suspension Adapter Anchor	2	—		35066	35015	
627-116	Loose End Nut	1	82638	82639			
627-117	Suspension Adapter Nut	2	927755			935791	
627-118	Chain Guide	1	27008	35018			
627-302	Liftwheel	1	27360	35421			
627-307	Liftwheel Bearing-Gear End	1	88429	82002			
627-308	Liftwheel Bearing-Motor End	1	88429	83669			
627-740	Loose End Screw	1	927764	987210			
627-741	Loose End Screw Lockwasher	1	982226	945851			
627-742	Loose End Screw Washer	1	954802	954807			
627-743	Loose End Link	1	27351	35367			
627-750	Load Chain (Specify Qty Required)	As Req'd.					
	Burnished in Oil		85889	85979			
	Zinc		85944	85949			
	Ni clad		85915	85916			
	Stainless Steel		85952	n/a			
	Zinc Phosphate		85965	85966			
627-837	Contact Block	1	—	—	—	36764	—
627-1030	Dead End Block Hole Plug (For use on Entertainment/Black Units Only)	1	27223	—	—	35291	—

ENGLISH

LODESTAR HOIST MOTOR END COMPONENTS

MODELS A, A-2, AA, B, B-2, C, C-2, E, E-2, F, F-2, H, H-2

ENGLISH

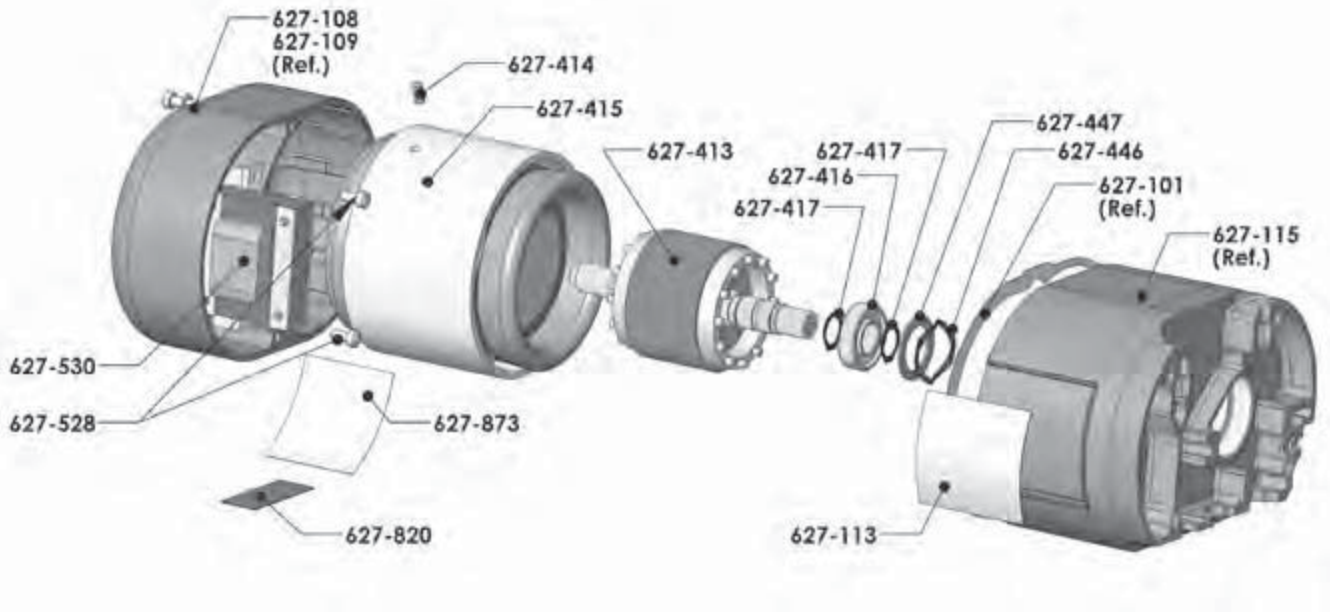

MODELS J, J-2, JJ, JJ-2, L, L-2, LL, LL-2, R, R-2, RR, RR-2, RT, RT-2, RRT, RRT-2

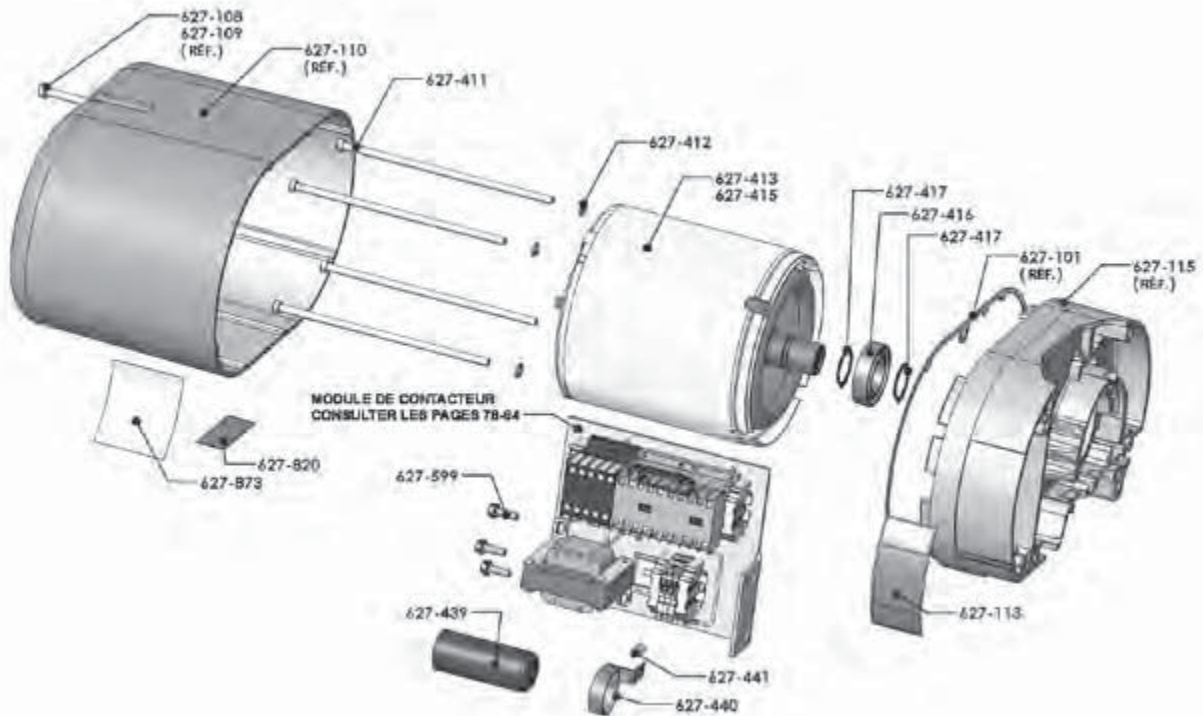

MOTOR END COMPONENTS

ENGLISH

Key Number	Part Name	No. Req'd	Models	
			A, A-2, AA, AA-2, B, B-2, C, C-2, F, F-2, H, H-2	J, J-2, JJ, JJ-2, L, L-2, LL, LL-2, R, R-2, RR, RR-2, RT, RT-2, RRT, RRT-2
			Part Number	
627-113	Identification Plate	1	Contact Factory	
627-411	Motor Attaching Screw	4	—	See Pg. 51
627-412	Motor Attaching Screw Lockwasher	4	982226	
627-413	Rotor and Shaft Sub Assembly	1	See Pg. 51	—
627-414	Stator Pin	1	983541	—
627-415	Stator	1	See Pg. 51	
627-415A	Motor End Plate	1	—	36023
627-416	Motor Shaft Bearing - Inboard End	1	82003	82004
627-417	Motor Shaft Bearing Snap Ring-Inboard End	2	27790	35764
627-439	Solid State Reversing Switch	1	27257 (115/230-1-50/60 Units)	35499 (115/230-1-50/60 Units)
627-440	Switch Clamp	1	27295	27275
627-441	Switch Clamp Screw	1	982873	
627-446	Rotor Wave Washer	1	27292	—
627-447	Rotor Bearing Spacer	1	27291	Contact Factory
627-528	Transformer Attaching Screws	2	982688	
627-530	Transformer & Bracket Mounting Assembly	1		
	V1 Single Phase Units 110/115-1-50/60 *Units w/Transformer		115 Volt Primary with 48 Volt Secondary code 29847	
			115 Volt Primary with 24 Volt Secondary code 29849	
			115 Volt Primary with 48 Volt Secondary w/Thermal Cutout for CSA use code 29848	
			115 Volt Primary with 24 Volt Secondary w/Thermal Cutout for CSA use code 28999	
	V1 Single Phase Units 220/230-1-50/60		220/230 Volt Primary with 115 Volt Secondary code 27771	
			220/230 Volt Primary with 48 Volt Secondary code 28850	
			220/230 Volt Primary with 24 Volt Secondary code 27780	
			220/230 Volt Primary with 115 Volt Secondary w/Thermal Cutout for CSA use code 27778	
			220/230 Volt Primary with 48 Volt Secondary w/Thermal Cutout for CSA use code 27777	
			220/230 Volt Primary with 24 Volt Secondary w/Thermal Cutout for CSA use code 28980	
			230/460 Volt Primary with 115 Volt Secondary code 27771	
			230/460 Volt Primary with 48 Volt Secondary code 28850	
	V1 Three Phase Units *All Three Phase Voltages		230/460 Volt Primary with 24 Volt Secondary code 27780	
			230/460 Volt Primary with 115 Volt Secondary w/Thermal Cutout for CSA use code 27778	
			230/460 Volt Primary with 48 Volt Secondary w/Thermal Cutout for CSA use code 27777	
			230/460 Volt Primary with 24 Volt Secondary w/Thermal Cutout for CSA use code 28980	
			550/575 Volt Primary with 115 Volt Secondary w/Thermal Cutout for CSA use code 27792	
			550/575 Volt Primary with 48 Volt Secondary w/Thermal Cutout for CSA use code 28798	
			550/575 Volt Primary with 24 Volt Secondary w/Thermal Cutout for CSA use code 28796	
627-599	Contacting Mounting Plate Screw	3	—	983656
627-820	Electrical Warning Label	1	24842	
627-873	Chain Label	1	928894	

CONTACTOR PLATE ASSEMBLIES

MODELS A, AA, B, C, E, F, H
SINGLE PHASE
110/115-1/50/60

ENGLISH

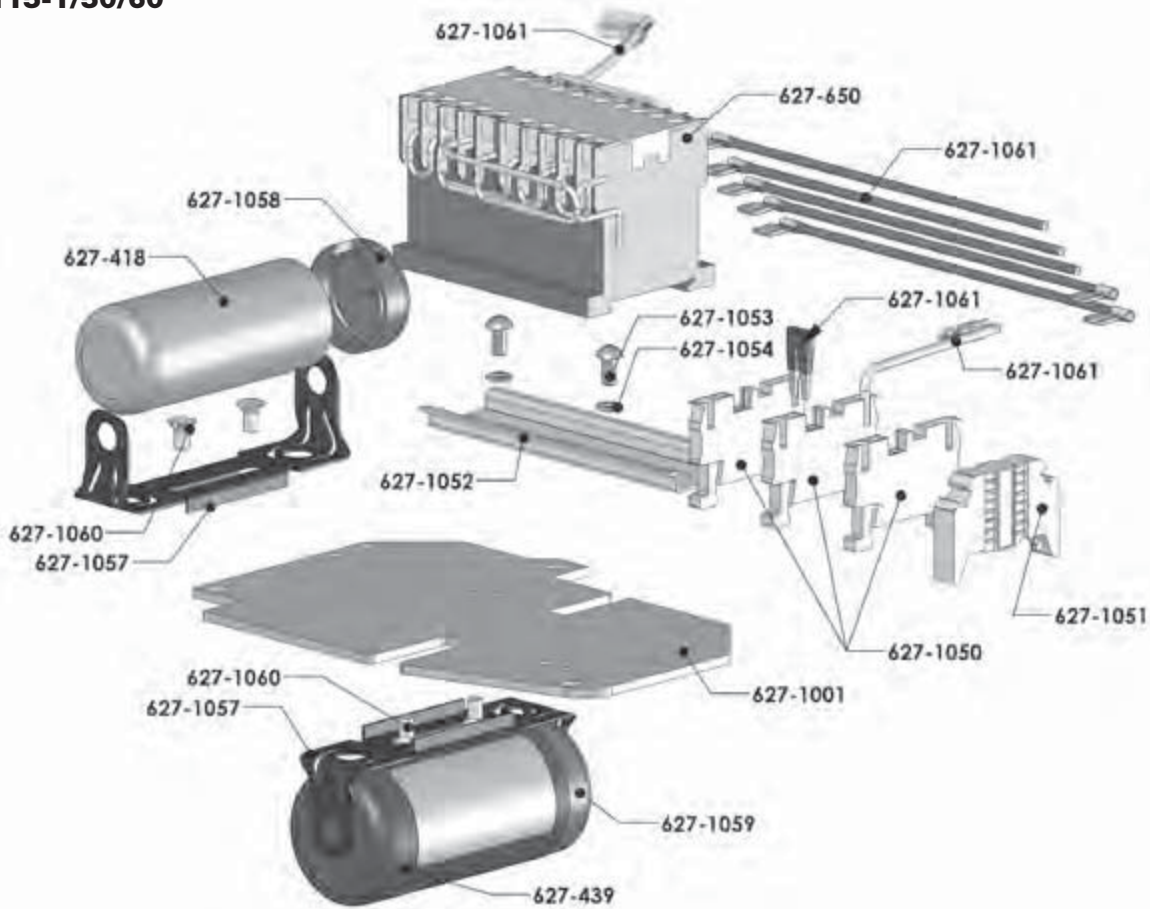

Key Number	Part Name	No. Req'd	Part Number
627-418	Capacitor	1	27716
627-439	Solid State Reversing Switch	1	27257
627-650	Hoist Reversing Contactor	1	28553 (115 Volt Coil)
627-1001	Contactor Mounting Plate	1	31633
627-1050	Terminal Strip	3	29014
627-1051	Terminal Strip End Clamp	1	29015
627-1052	Din Rail Mounting Bracket	1	29312
627-1053	Din Rail Mounting Bracket Screw	2	982686
627-1054	Din Rail Mounting Bracket Screw Lockwasher	2	987873
627-1057	Capacitor Mounting Bracket or Solid State Reversing Switch Mounting Bracket	2	27910
627-1058	Insulating Capacitor Cap	1	29910
627-1059	Insulating Solid State Reversing Switch Cap	1	27925
627-1060	Capacitor Mounting Bracket or Solid State Reversing Switch Mounting Bracket Screw	4	982696
627-1061	Jumpers:		
	R5	1	29911
	R6	1	29912
	R7	1	29913
	R8	1	29914
	R14	1	27156
	B1	1	29915
	B2	1	29916
	Bridge	1	29047
Wiring Harness	1	29926	



CONTACTOR PLATE ASSEMBLIES

MODELS A, AA, B, C, E, F, H
SINGLE PHASE WITH TRANSFORMER
110/115-1/50/60

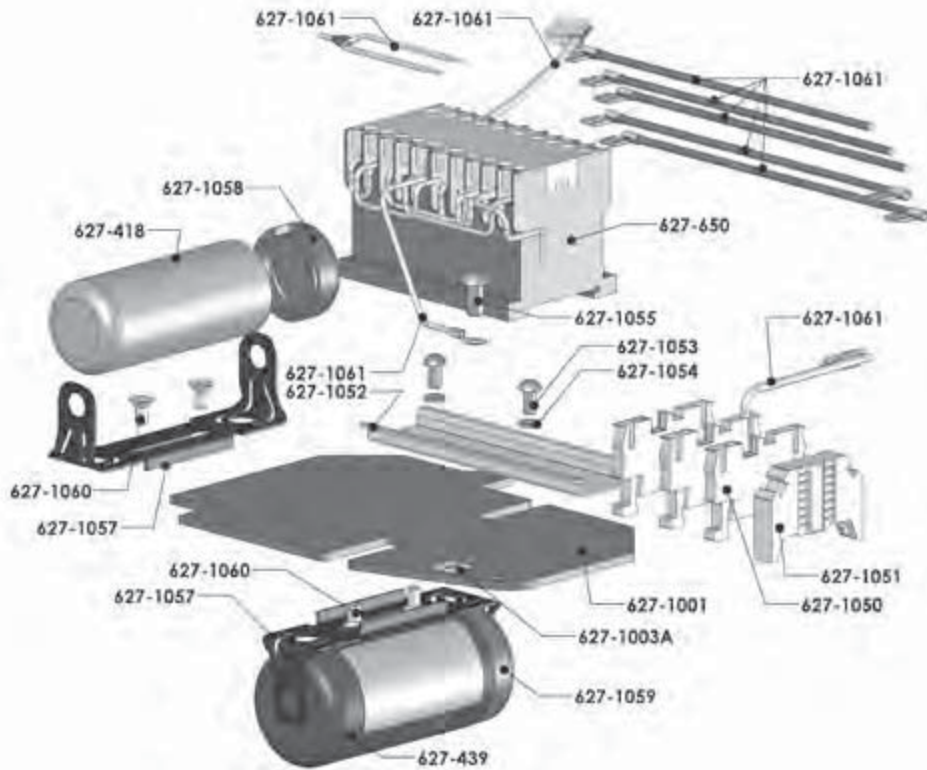

Key Number	Part Name	No. Req'd	Part Number
627-418	Capacitor	1	27716
627-439	Solid State Reversing Switch	1	27257
627-650	Hoist Reversing Contactor	1	28545 (48 Volt Coil) 28552 (24 Volt Coil)
627-1001	Contactor Mounting Plate	1	31633
627-1003A	Ground Label	1	20940
627-1050	Terminal Strip	3	29014
627-1051	Terminal Strip End Clamp	1	29015
627-1052	Din Rail Mounting Bracket	1	29312
627-1053	Din Rail Mounting Bracket Screw	2	982686
627-1054	Din Rail Mounting Bracket Screw Lockwasher	2	987873
627-1055	Ground Screw	1	987827
627-1057	Capacitor Mounting Bracket or Solid State Reversing Switch Mounting Bracket	2	27910
627-1058	Insulating Capacitor Cap	1	29910
627-1059	Insulating Solid State Reversing Switch Cap	1	27925
627-1060	Capacitor Mounting Bracket or Solid State Reversing Switch Mounting Bracket Screw	4	982696
627-1061	Jumpers:		
	R5	1	29911
	R6	1	29912
	R7	1	29913
	R8	1	29914
	R14	1	27156
	B1	1	29915
	B2	1	29916
	G-Y	1	27189
	Jumper Assembly	1	29929
	Wiring Harness	1	29927

CONTACTOR PLATE ASSEMBLIES

MODELS A, AA, B, C, E, F, H
SINGLE PHASE
220/230-1-50/60

ENGLISH

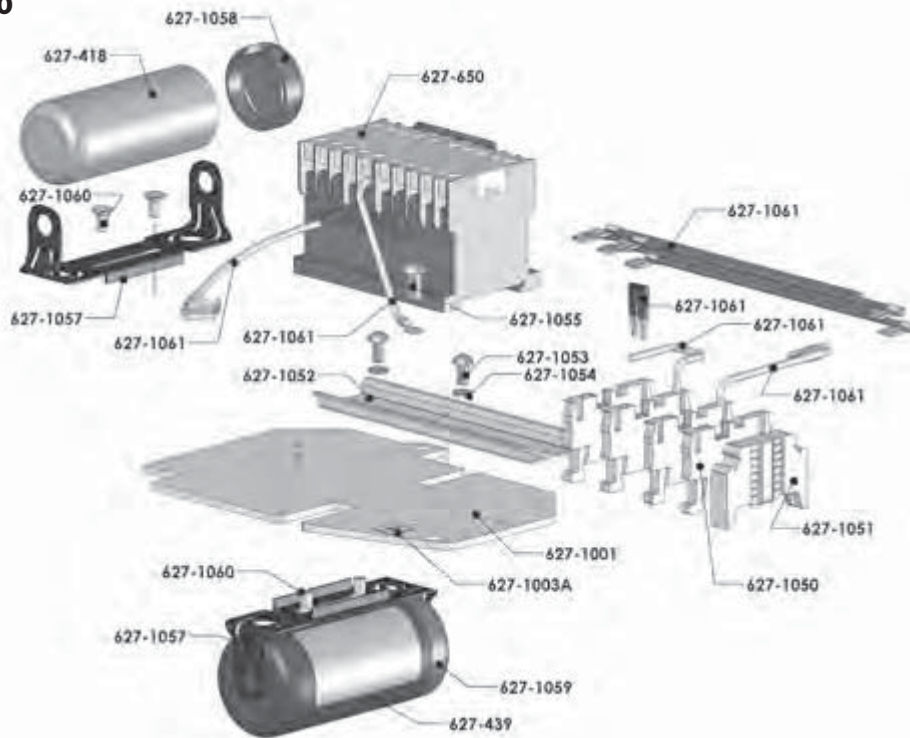

Key Number	Part Name	No. Req'd	Part Number
627-418	Capacitor	1	27716
627-439	Solid State Reversing Switch	1	27257
627-650	Hoist Reversing Contactor	1	28553 (110 Volt Coil) 28545 (48 Volt Coil) 28552 (24 Volt Coil)
627-1001	Contactor Mounting Plate	1	31633
627-1003A	Ground Label	1	20940
627-1050	Terminal Strip	4	29014
627-1051	Terminal Strip End Clamp	1	29015
627-1052	Din Rail Mounting Bracket	1	29312
627-1053	Din Rail Mounting Bracket Screw	2	982686
627-1054	Din Rail Mounting Bracket Screw Lockwasher	2	987873
627-1055	Ground Screw	1	987827
627-1057	Capacitor Mounting Bracket or Solid State Reversing Switch Mounting Bracket	2	27910
627-1058	Insulating Capacitor Cap	1	29910
627-1059	Insulating Solid State Reversing Switch Cap	1	27925
627-1060	Capacitor Mounting Bracket or Solid State Reversing Switch Mounting Bracket Screw	4	982696
627-1061	Jumpers:		
	R5	1	29911
	R6	1	29912
	R7	1	29913
	R8	1	29914
	R14	1	27156
	B1	1	29915
	B2	1	29916
	Bridge	1	27047
	Contactor Jumper	1	51547
	G-Y	1	27189
	Wiring Harness	1	29928

CONTACTOR PLATE ASSEMBLIES

MODELS A, AA, B, C, E, F, H
THREE PHASE, DUAL VOLTAGE
220/230-3-50/60 380/415/460-3-50/60

ENGLISH

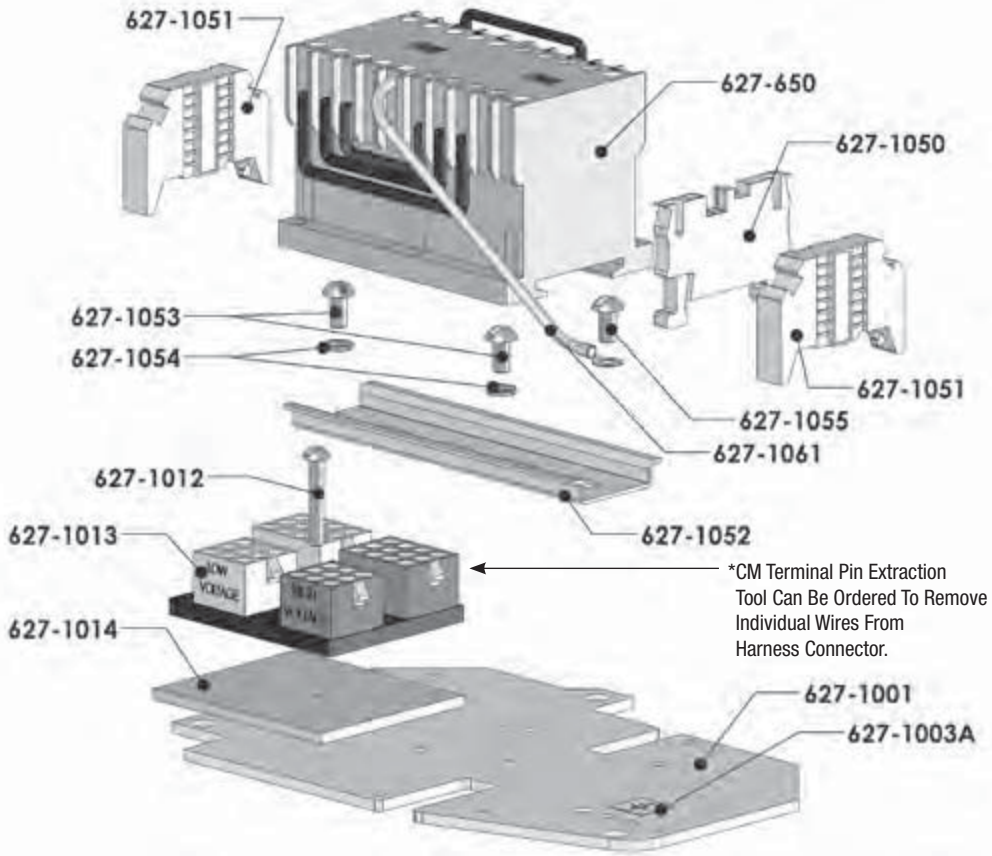

Key Number	Part Name	No. Req'd	Part Number
627-650	Hoist Reversing Contactor	1	24799 (110 Volt Coil) 24797 (48 Volt Coil) 28860 (24 Volt Coil)
627-1001	Contactor Mounting Plate	1	31633
627-1003A	Ground Label	1	20940
627-1012	Voltage Change Board Mounting Screw	1	987862
627-1013	Voltage Change Board	1	27672
627-1014	Voltage Change Board Insulator	1	27685
627-1050	Terminal Strip	1	29014
627-1051	Terminal Strip End Clamp	2	29015
627-1052	Din Rail Mounting Bracket	1	29312
627-1053	Din Rail Mounting Bracket Screw	2	982686
627-1054	Din Rail Mounting Bracket Screw Lockwasher	2	987873
627-1055	Ground Screw	1	987827
627-1061	Jumper:		
	G-Y	1	27189
	Motor Wiring Harness	1	27603
	Wiring Harness	1	29801
*627-1063	CM Terminal Pin Extraction Tool (Not Shown)	1	27163

CONTACTOR PLATE ASSEMBLIES

MODELS A-2, AA-2, B-2, C-2, E-2, F-2 & H-2

THREE PHASE, TWO SPEED

220/230-3-50/60, 380/415/460-3-50/60, 550/575-3-50/60

ENGLISH

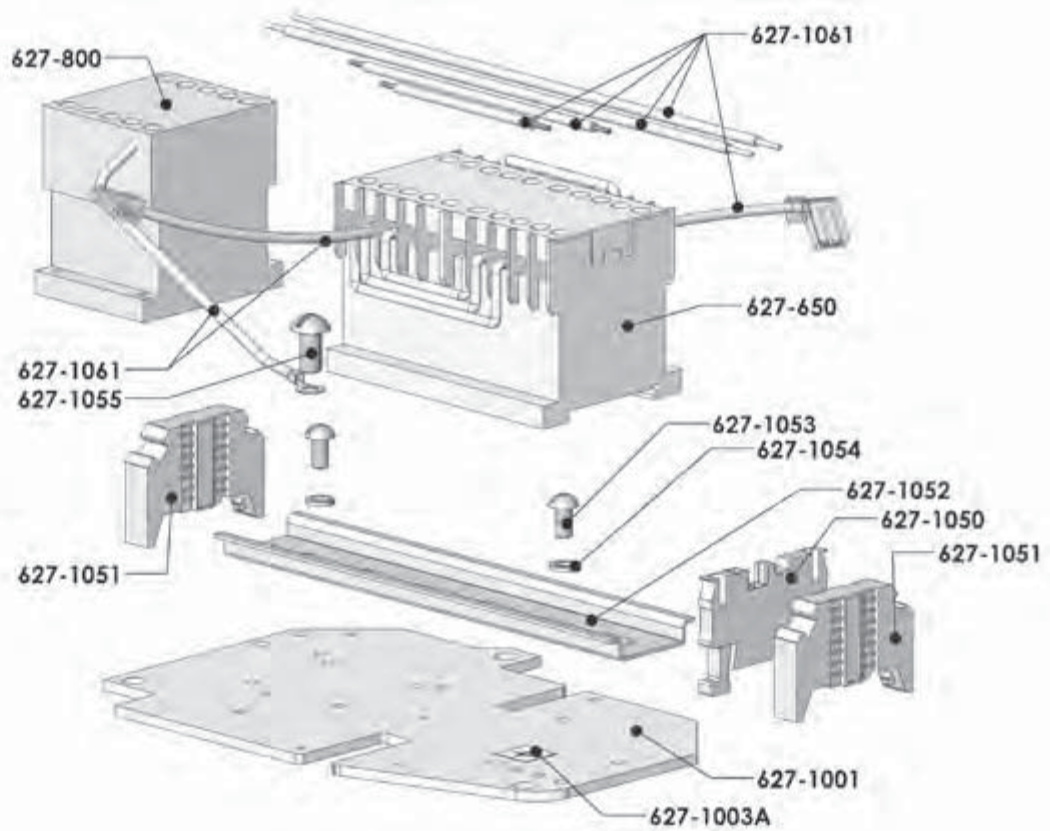

Key Number	Part Name	No. Req'd	Part Number
627-650	Hoist Reversing Contactor	1	28553 (115 Volt Coil) 24797 (48 Volt Coil) 28860 (24 Volt Coil)
627-800	Hoist Speed Selecting Contactor	1	28870 (115 Volt Coil) 28871 (48 Volt Coil) 28878 (24 Volt Coil)
627-1001	Contactor Mounting Plate	1	31633
627-1003A	Ground Label	1	20940
627-1050	Terminal Strip	1	29014
627-1051	Terminal Strip End Clamp	2	29015
627-1052	Din Rail Mounting Bracket	1	29312
627-1053	Din Rail Mounting Bracket Screw	2	982686
627-1054	Din Rail Mounting Bracket Screw Lockwasher	2	987873
627-1055	Ground Screw	1	987827
627-1061	Jumpers:		
	R10	1	27609
	R13	1	27610
	B1	1	29915
	B2	1	29916
	Contactor Jumper	2	51845
	Contactor Jumper	2	51847
	G-Y	1	27189
	Wiring Harness	1	29802

CONTACTOR PLATE ASSEMBLIES

MODELS A, AA, B, B-2, C, E, F, H
THREE PHASE
550/575-3-50/60

ENGLISH

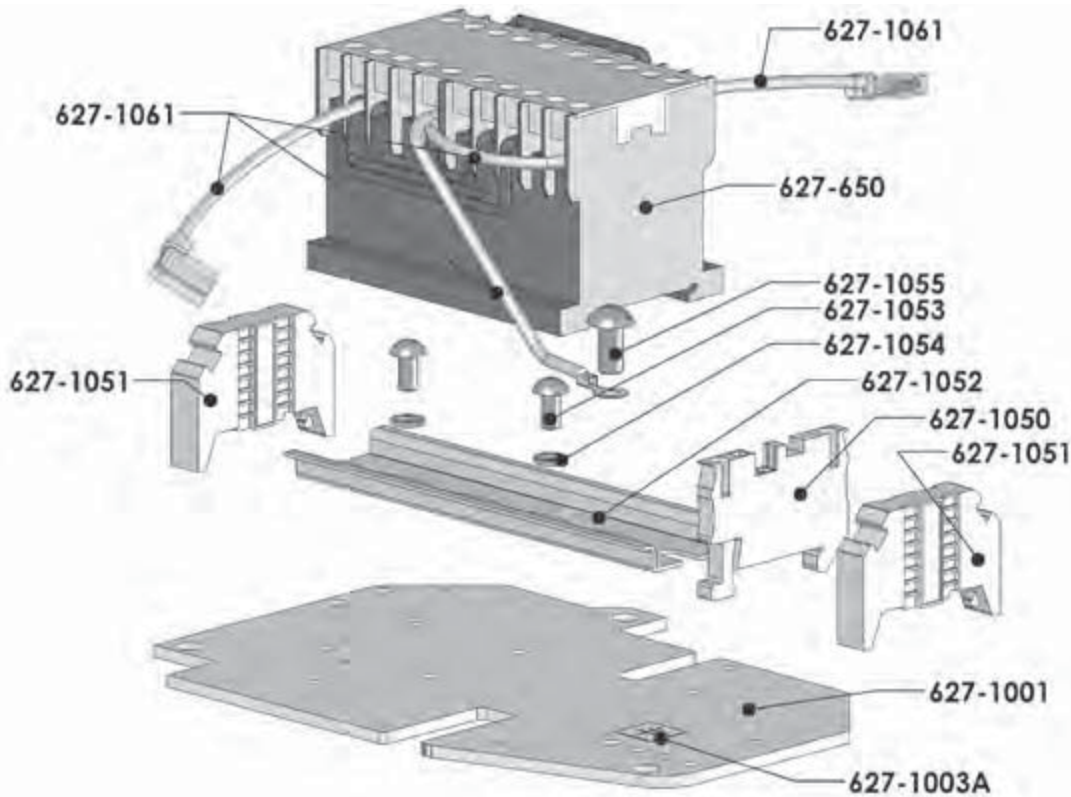

Key Number	Part Name	No. Req'd	Part Number
627-650	Hoist Reversing Contactor	1	24799(115 Volt Coil) 24797 (48 Volt Coil) 28860 (24 Volt Coil)
627-1001	Contactor Mounting Plate	1	31633
627-1003A	Ground Label	1	20940
627-1050	Terminal Strip	1	29014
627-1051	Terminal Strip End Clamp	2	29015
627-1052	Din Rail Mounting Bracket	1	29312
627-1053	Din Rail Mounting Bracket Screw	2	982686
627-1054	Din Rail Mounting Bracket Screw Lockwasher	2	987873
627-1055	Ground Screw	1	987827
627-1061	Jumpers:		
	B1	1	29915
	B2	1	29916
	Contactor Jumper	1	51847
	G-Y	1	27189
	Wiring Harness	1	27160

CONTACTOR PLATE ASSEMBLIES

**MODELS J, L, R & RT
SINGLE PHASE
110/115-1-50/60**

ENGLISH

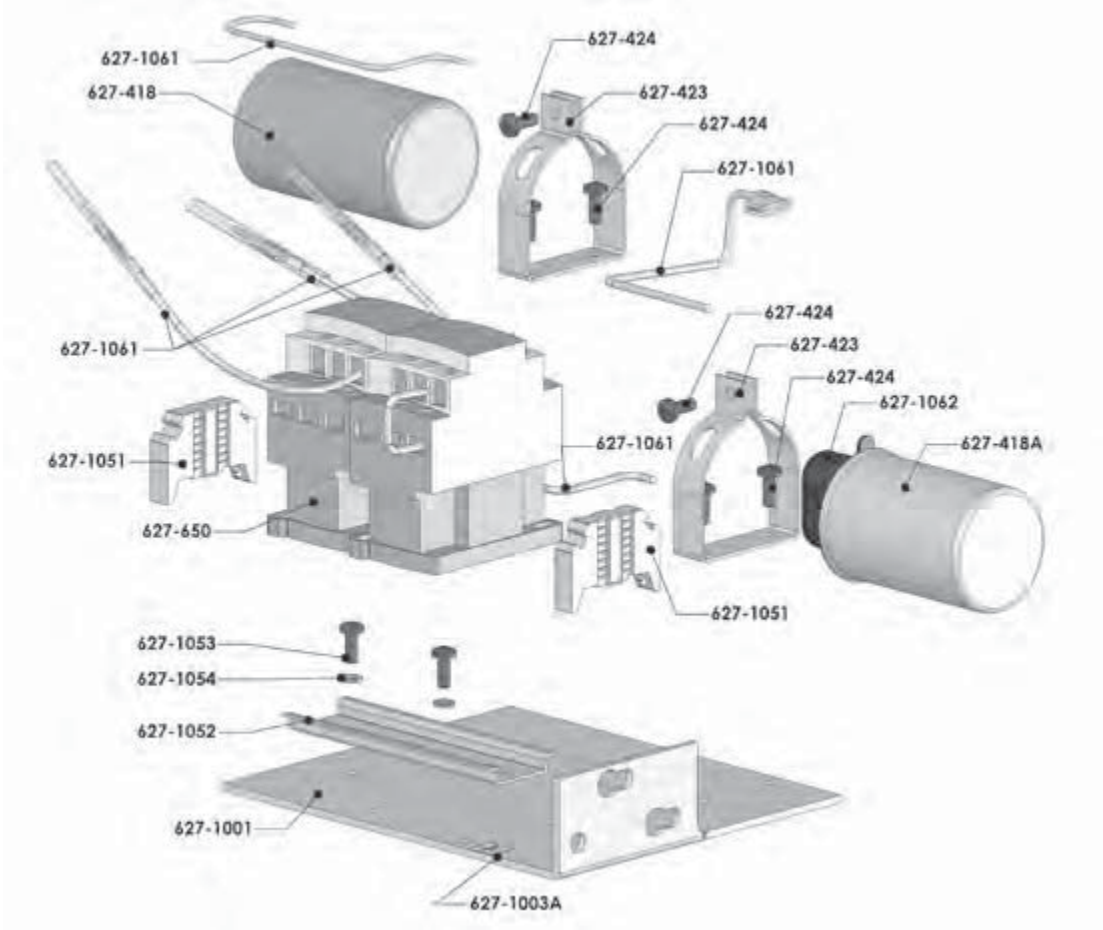

Key Number	Part Name	No. Req'd	Part Number
627-418	Start Capacitor	1	35279
627-418A	Run Capacitor	1	35278
627-423	Start/Run Capacitor Mounting Clamp	2	35268
627-424	Mounting Clamp Screw	6	982873
627-650	Hoist Reversing Contactor	1	27142 (115 Volt Coil) 27138 (48 Volt Coil) 27139 (24 Volt Coil)
627-1001	Contactor Mounting Plate	1	29013
627-1003A	Ground Label	1	20940
627-1051	Terminal Strip End Clamp	2	29015
627-1052	Din Rail Mounting Bracket	1	29009
627-1053	Din Rail Mounting Bracket Screw	2	982686
627-1054	Din Rail Mounting Bracket Screw Lockwasher	2	987873
627-1061	Jumpers:		
	R2	1	29036
	R3	1	29037
	R4	1	29035
	R5	1	29038
	R10	1	29034
	Contactor Jumper	1	51845
627-1062	Wiring Harness	1	29039
627-1062	Rubber Insulating Boot	1	35285

CONTACTOR PLATE ASSEMBLIES

MODELS J, L, R & RT
SINGLE PHASE
220/230-1-50/60

ENGLISH

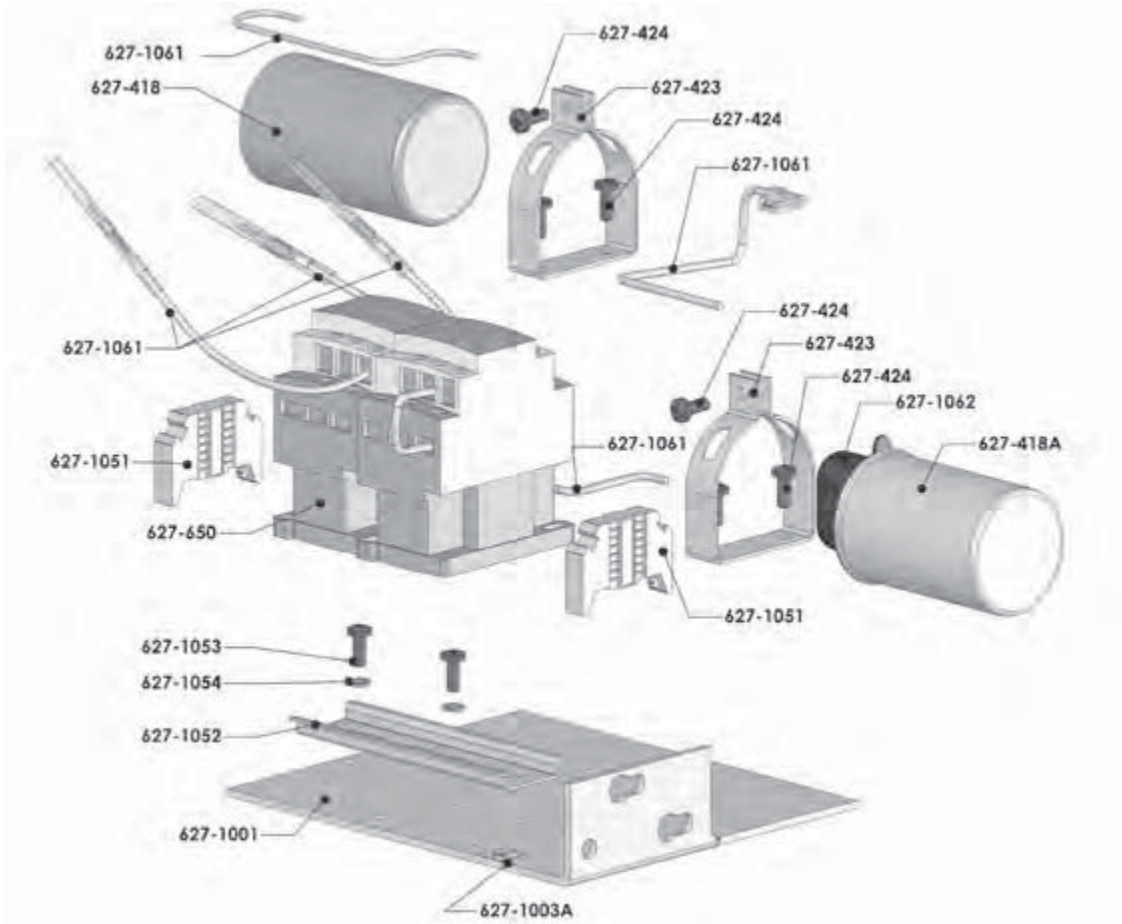

Key Number	Part Name	No. Req'd	Part Number
627-418	Start Capacitor	1	35279
627-418A	Run Capacitor	1	35278
627-423	Start/Run Capacitor Mounting Clamp	2	35268
627-424	Mounting Clamp Screw	6	982873
627-650	Hoist Reversing Contactor	1	27013 (115 Volt Coil) 27104 (48 Volt Coil) 27105 (24 Volt Coil)
627-1001	Contactor Mounting Plate	1	29013
627-1003A	Ground Label	1	20940
627-1051	Terminal Strip End Clamp	2	29015
627-1052	Din Rail Mounting Bracket	1	29009
627-1053	Din Rail Mounting Bracket Screw	2	982686
627-1054	Din Rail Mounting Bracket Screw Lockwasher	2	987873
627-1061	Jumpers:		
	R2	1	29036
	R3	1	29037
	R4	1	29035
	R5	1	29038
	R9	1	29113
	R10	1	29034
	G-Y	1	27189
	Wiring Harness	1	29044
627-1062	Rubber Insulating Boot	1	35285

CONTACTOR PLATE ASSEMBLIES

**MODELS J, JJ, L, LL, R, RR, RT & RRT
THREE PHASE, DUAL VOLTAGE
220/230-3-50/60, 380/415/460-3-50/60**

*CM Terminal Pin Extraction Tool Can Be Ordered To Remove Individual Wires From Motor/Harness Connector.

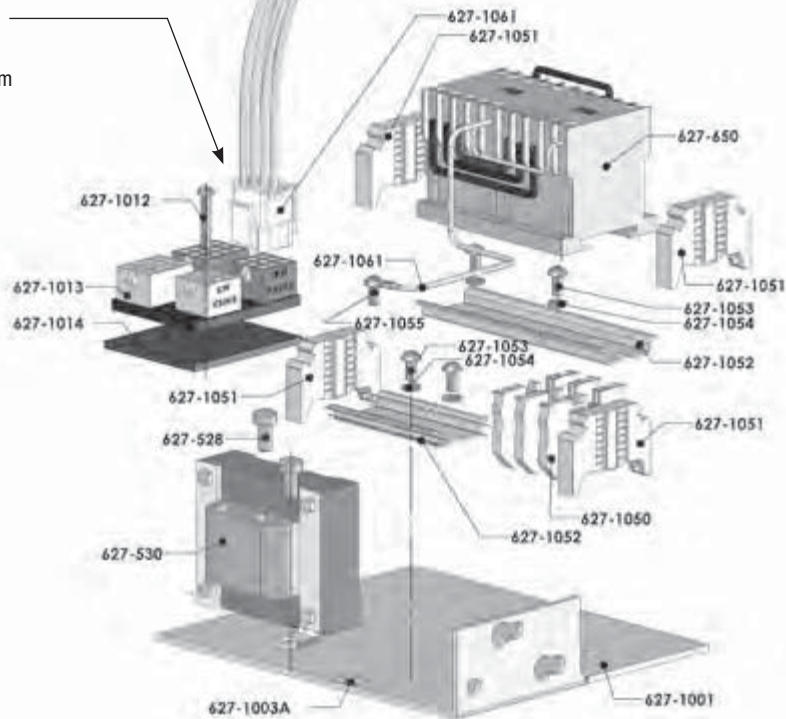

Key Number	Part Name	No. Req'd	Part Number
627-528	Transformer Mounting Screw	2	982688
627-530	Transformer	1	29734 (115 V Secondary) 29756 (48 V Secondary) 29809 (24 V Secondary) 29811 (115 V Secondary with Thermal Cutout) 29983 (48 V Secondary with Thermal Cutout) 29982 (24 V Secondary with Thermal Cutout)
627-650	Hoist Reversing Contactor	1	24799 (115 Volt Coil) 24797 (48 Volt Coil) 28860 (24 Volt Coil)
627-1001	Contactor Mounting Plate	1	29013
627-1003A	Ground Label	1	20940
627-1012	Conversion Board Mounting Screw	1	987862
627-1013	Conversion Board	1	27672
627-1014	Conversion Board Insulator	1	27685
627-1050	Terminal Strip	3	29014
627-1051	Terminal Strip End Clamp	4	29015
627-1052	Din Rail Mounting Bracket		
	Contactor Bracket	1	29009
	Terminal Strip Bracket	1	29008
627-1053	Din Rail Mounting Bracket Screw	4	982686
627-1054	Din Rail Mounting Bracket Screw Lockwasher	4	987873
627-1055	Ground Screw	1	987827
627-1061	Jumpers:		
	Contactor Jumper	1	51847
	G-Y	1	27189
	Wiring Harness	1	27102
	Wiring Harness	1	29670
*627-1063	CM Terminal Pin Extraction Tool (Not Shown)	1	21763

CONTACTOR PLATE ASSEMBLIES

**MODELS J-2, JJ-2, L-2, LL-2, R-2, RR-2, RT-2 & RRT-2
THREE PHASE, TWO SPEED
220/230-3-50/60**

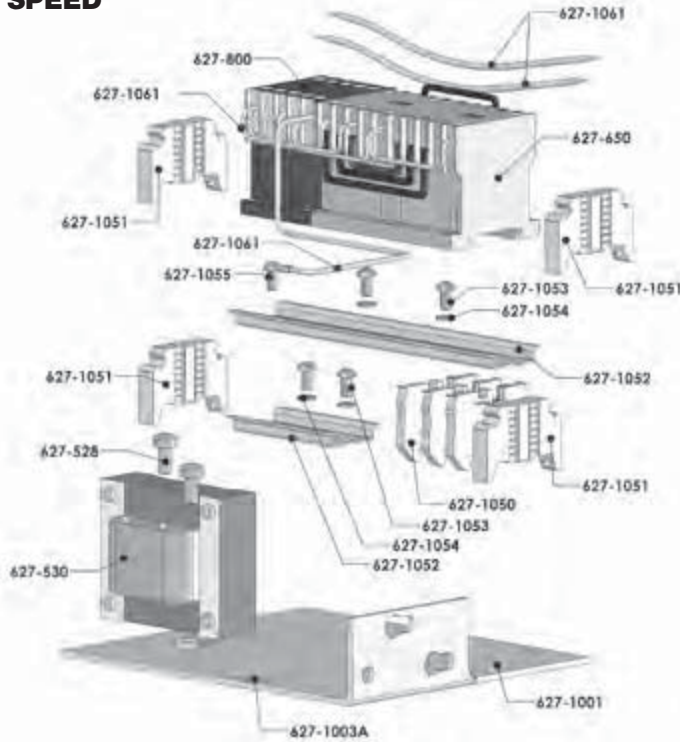

Key Number	Part Name	No. Req'd	Part Number
627-528	Transformer Mounting Screw	2	982688
627-530	Transformer	1	29734 (115 V Secondary) 29756 (48 V Secondary) 29809 (24 V Secondary) 29811 (115 V Secondary with Thermal Cutout) 29983 (48 V Secondary with Thermal Cutout) 29982 (24 V Secondary with Thermal Cutout)
627-650	Hoist Reversing Contactor	1	24799 (115 Volt Coil) 24797 (48 Volt Coil) 28860 (24 Volt Coil)
627-800	Hoist Speed Selecting Contactor	1	28870 (115 Volt Coil) 28871 (48 Volt Coil) 28878 (24 volt Coil)
627-1001	Contactor Mounting Plate	1	29013
627-1003A	Ground Label	1	20940
627-1050	Terminal Strip	3	29014
627-1051	Terminal Strip End Clamp	4	29015
627-1052	Din Rail Mounting Bracket		
	Contactor Bracket	1	29010
	Terminal Strip Bracket	1	29008
627-1053	Din Rail Mounting Bracket Screw	4	982686
627-1054	Din Rail Mounting Bracket Screw Lockwasher	4	987873
627-1055	Ground Screw	1	987827
627-1061	Jumpers:		
	R4	1	27652
	R5	1	27657
	R7	1	27760
	R8	1	27762
	W5	1	27736
	G-Y	1	27189
	Speed Selector Jumper	2	51845
	Wiring Harness	1	27897

CONTACTOR PLATE ASSEMBLIES

**MODELS J-2, JJ-2, L-2, LL-2, R-2, RR-2, RT-2 & RRT-2
THREE PHASE, TWO SPEED
380/415/460-3-50/60**

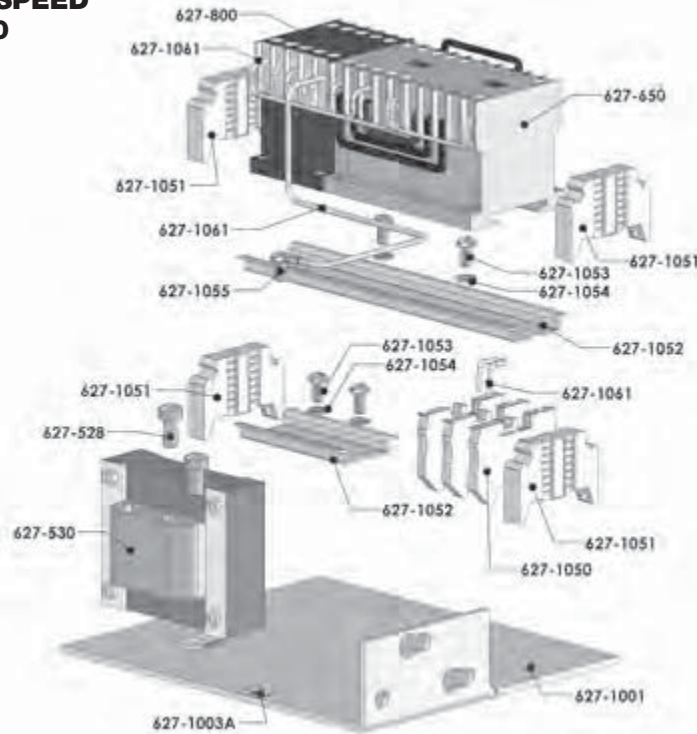

Key Number	Part Name	No. Req'd	Part Number
627-528	Transformer Mounting Screw	2	982688
627-530	Transformer	1	29734 (115 V Secondary) 29756 (48 V Secondary) 29809 (24 V Secondary) 29811 (115 V Secondary with Thermal Cutout) 29983 (48 V Secondary with Thermal Cutout) 29982 (24 V Secondary with Thermal Cutout)
627-650	Hoist Reversing Contactor	1	24799 (115 Volt Coil) 24797 (48 Volt Coil) 28860 (24 Volt Coil)
627-800	Host Speed Selecting Contactor	1	28870 (115 Volt Coil) 28871 (48 Volt Coil) 28878 (24 Volt Coil)
627-1001	Contactor Mounting Plate	1	29013
627-1003A	Ground Label	1	20940
627-1050	Terminal Strip	3	29014
627-1051	Terminal Strip End Clamp	4	29015
627-1052	Din Rail Mounting Bracket		
	Contactor Bracket	1	29010
	Terminal Strip Bracket	1	29008
627-1053	Din Rail Mounting Bracket Screw	4	982686
627-1054	Din Rail Mounting Bracket Screw Lockwasher	4	987873
627-1055	Ground Screw	1	987827
627-1061	Jumpers:		
	R4	1	27652
	R5	1	27657
	W5	1	27736
	G-Y	1	27189
	Contactor Jumper	1	51847
	Terminal Strip Jumper	1	51845
	Speed Selector Jumper	2	51845
Wiring Harness	1	29600	

CONTACTOR PLATE ASSEMBLIES

**MODELS J, JJ, L, LL, R, RR, RT & RRT
THREE PHASE, SINGLE SPEED
550/575-3-50/60**

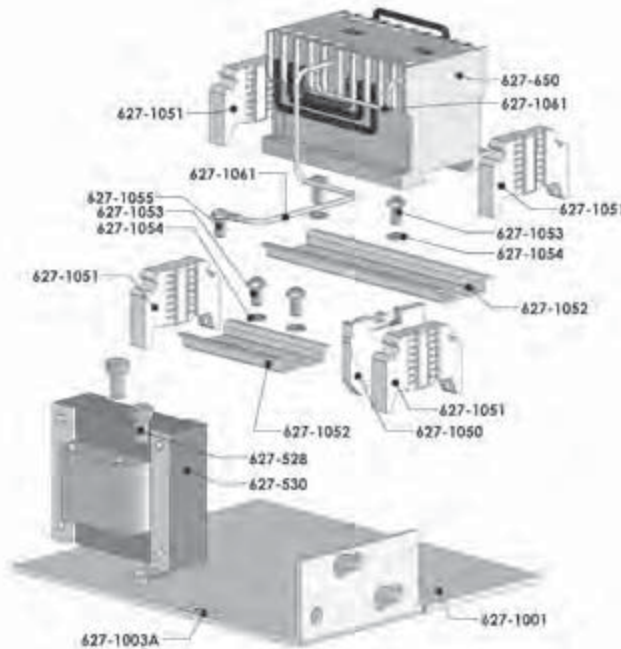

Key Number	Part Name	No. Req'd	Part Number
627-528	Transformer Mounting Screw	2	982688
627-530	Transformer	1	29807 (115 V Secondary) 29805 (115 V Secondary with Thermal Cutout) 29789 (48 V Secondary with Thermal Cutout) 29984 (24 V Secondary with Thermal Cutout)
627-650	Hoist Reversing Contactor	1	24799 (115 Volt Coil) 24797 (48 Volt Coil) 28860 (24 Volt Coil)
627-1001	Contactor Mounting Plate	1	29013
627-1003A	Ground Label	1	20940
627-1050	Terminal Strip	1	29014
627-1051	Terminal Strip End Clamp	4	29015
627-1052	Din Rail Mounting Bracket		
	Contactor Bracket	1	29009
	Terminal Strip Bracket	1	29008
627-1053	Din Rail Mounting Bracket Screw	4	982686
627-1054	Din Rail Mounting Bracket Screw Lockwasher	4	987873
627-1055	Ground Screw	1	987827
627-1061	Jumpers:		
	Contactor Jumper	1	51847
	G-Y	1	27189
	Wiring Harness	1	29601

CONTACTOR PLATE ASSEMBLIES

**MODELS J-2, JJ-2, L-2, LL-2, R-2, RR-2, RT-2 & RRT-2
THREE PHASE, TWO SPEED
550/575-3-50/60**

ENGLISH

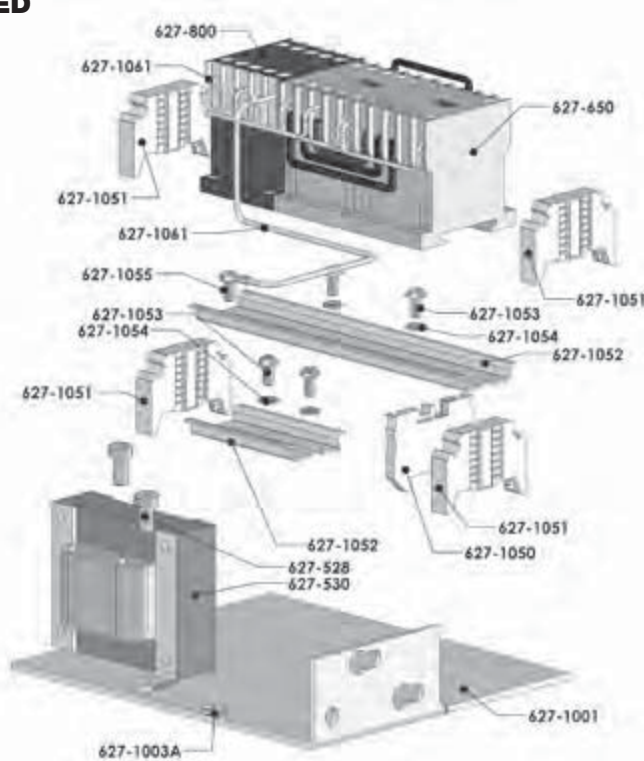

Key Number	Part Name	No. Req'd	Part Number
627-528	Transformer Mounting Screw	2	982688
627-530	Transformer	1	29807 (115 V Secondary) 29805 (115 V Secondary with Thermal Cutout) 29789 (48 V Secondary with Thermal Cutout) 29984 (24 V Secondary with Thermal Cutout)
627-650	Hoist Reversing Contactor	1	24799 (115 Volt Coil) 24797 (48 Volt Coil) 28860 (24 Volt Coil)
627-800	Host Speed Selecting Contactor	1	28870 (115 Volt Coil) 28871 (48 Volt Coil) 28878 (24 Volt Coil)
627-1001	Contactor Mounting Plate	1	29013
627-1003A	Ground Label	1	20940
627-1050	Terminal Strip	1	29014
627-1051	Terminal Strip End Clamp	4	29015
627-1052	Din Rail Mounting Bracket		
	Contactor Bracket	1	29009
	Terminal Strip Bracket	1	29008
627-1053	Din Rail Mounting Bracket Screw	4	982686
627-1054	Din Rail Mounting Bracket Screw Lockwasher	4	987873
627-1055	Ground Screw 1	1	987827
627-1061	Jumpers:		
	R4	1	27652
	R5	1	27657
	W5	1	27736
	Contactor Jumper	2	51845
	Contactor Jumper	1	v51847
	G-Y	1	27189
Wiring Harness	1	29600	

LODESTAR HOIST CONTROL STATION

627-450 COMPLETE CONTROL CORD AND STATION ASSEMBLY SINGLE SPEED HOIST CONTROL STATION

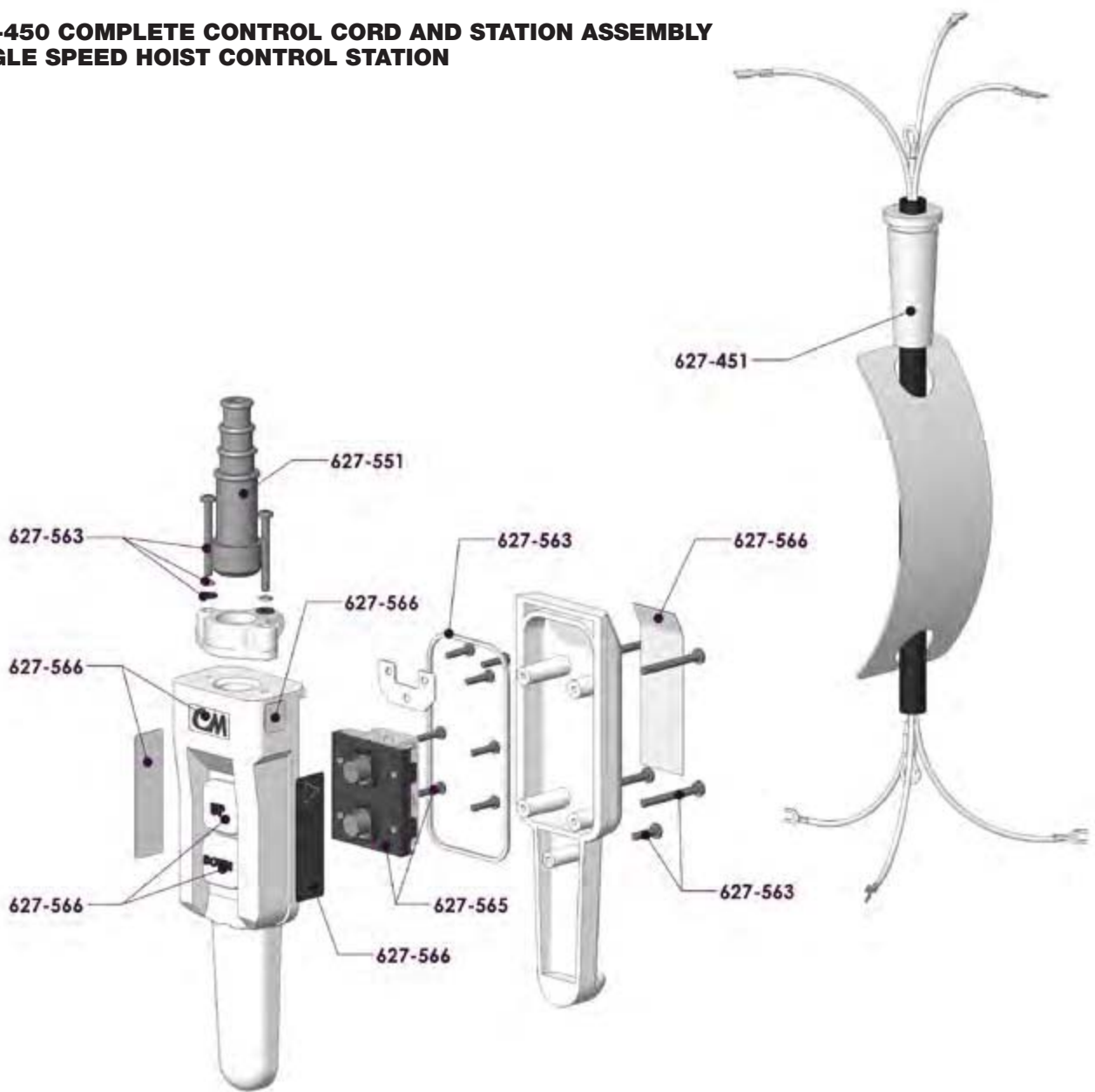

ENGLISH

Key Number	Part Name	No. Req'd	Part Number
627-450	Control Cord and Station Assembly	1	29333 for 10' Lift 29334 for 15' Lift 29335 for 20' Lift 29336 for 10' Lift for CSA Units
627-451	Standard Control Cord Assembly	1	29350 for 10' Lift 29351 for 15' Lift 29352 for 20' Lift 29353 for 10' Lift for CSA Units
627-551	Control Station Grommet	1	58278
627-552	Control Station (Includes 627-551 thru 627-567)	1	58272
627-563	Control Station Hardware Kit w/gasket	1	58275
627-565	Control Station 1-speed Insert	1	58255
627-566	Control Station Warning Label Kit (Includes Exterior Labels)	1	58276
627-567	Control Station Button Label Kit	1	58277

LODESTAR HOIST CONTROL STATION

627-450 COMPLETE CONTROL CORD AND STATION ASSEMBLY TWO SPEED HOIST CONTROL STATION

ENGLISH

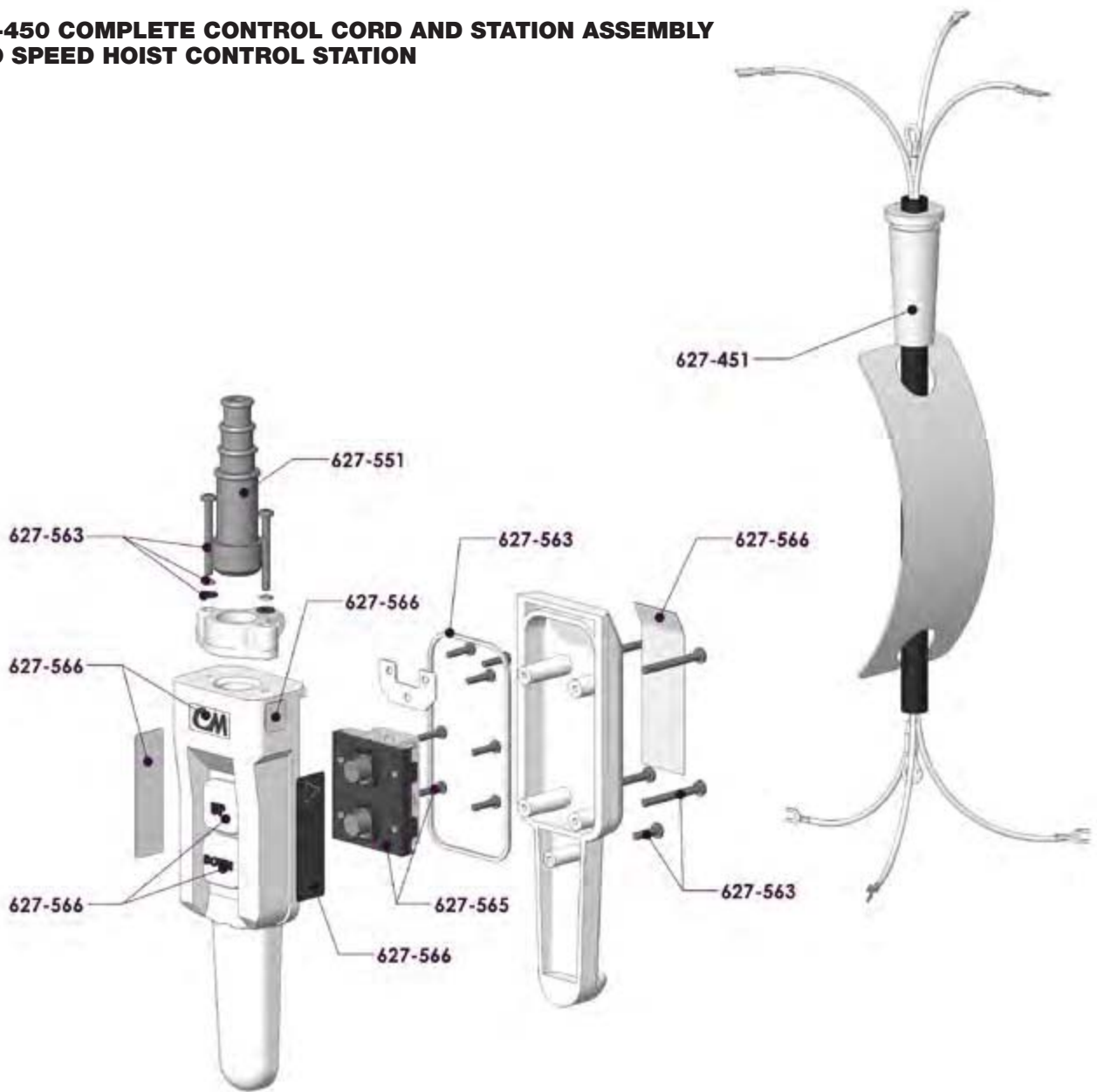

Key Number	Part Name	No. Req'd	Part Number
627-450	Control Cord and Station Assembly	1	29337 for 10' Lift 29348 for 10' Lift for CSA Units
627-451	Standard Control Cord Assembly	1	29354 for 10' Lift 29349 for 10' Lift for CSA Units
627-551	Control Station Grommet	1	58278
627-552	Control Station (Includes 627-551 thru 627-567)	1	58273
627-563	Control Station Hardware Kit w/gasket	1	58275
627-565	Control Station 2-speed Insert	1	58256
627-566	Control Station Warning Label Kit (Includes Exterior Labels)	1	58276
627-567	Control Station Button Label Kit	1	58277

LODESTAR HOIST CONTROL STATION

627-450 COMPLETE CONTROL CORD AND STATION ASSEMBLY FOUR DIRECTIONAL HOIST CONTROL STATION

ENGLISH

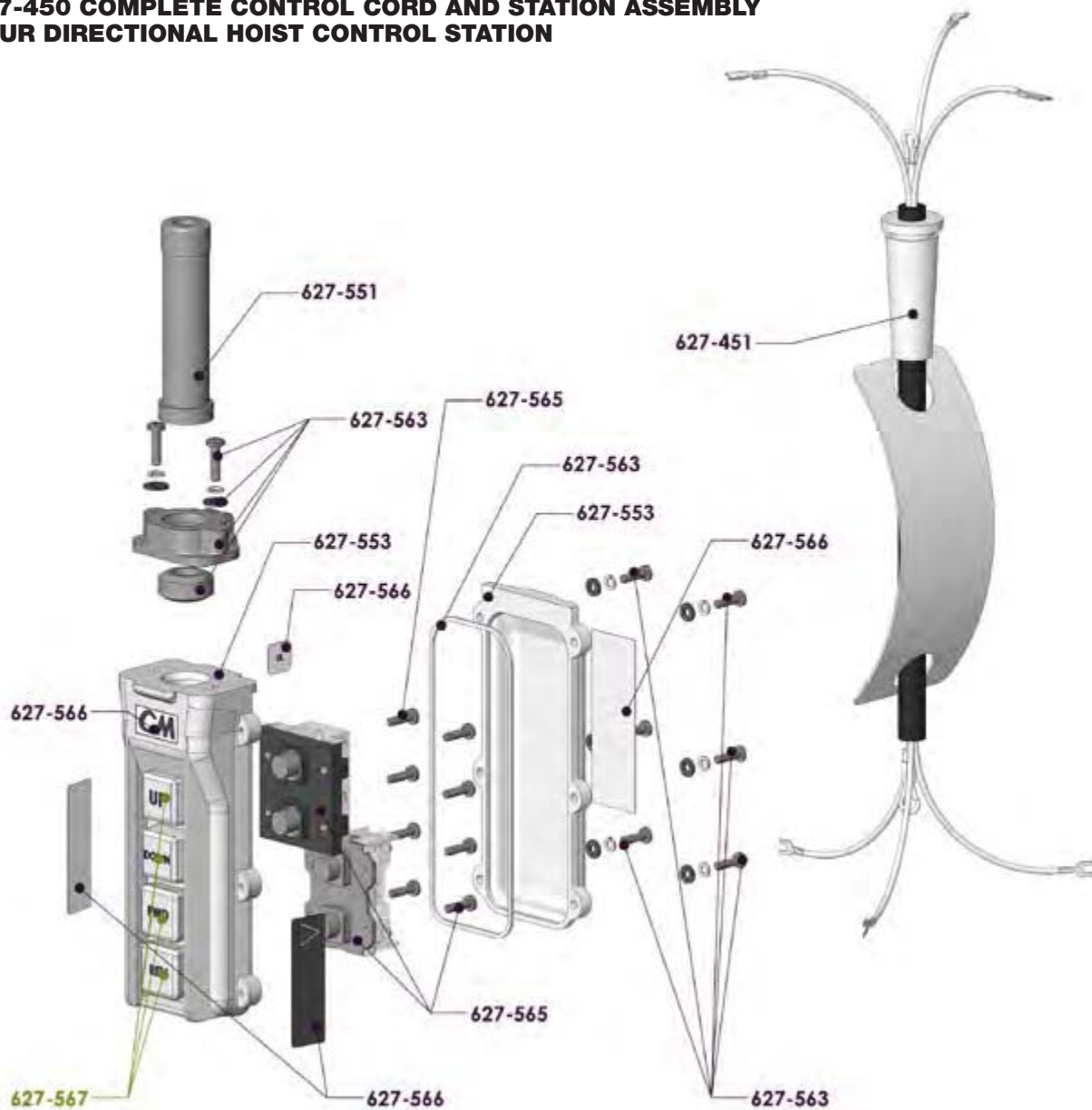

Key Number	Part Name	No. Req'd	Part Number
627-451	Standard Control Cord Assembly	1	51708
627-551	Control Station Grommet	1	58278
627-552	Control Station (Includes 627-551 Thru 627-567)	1	58220 CM
627-553	Control Station Housing Kit (Includes Housing, Boots, Collar, Gasket & Hardware)	1	58288
627-563	Control Station Hardware Kit w/gasket	1	58279
627-565	Control Station 1-Speed Insert	1	58255
	Control Station 2-Speed Insert	1	58256
627-566	Control Station Warning Label Kit	1	58276
627-567	Control Station Button Label Kit	1	58277